

Section Q

**MISCELLANEOUS**

**Index**

<b>No.</b>	<b>Part No.</b>		<b>Description</b>
1.	N.A.		Wooden Dowel (Purchase Locally)
2.	61-100053-006	N.A.	Carriages
3.	61-100055-006	N.A.	Cutter Bar
4.	11-386110-000	N.A.	Cutter Bar Support
5.	61-100052-003	N.A.	Tape Hub
6.	11-106533-000		Shoulder Bolt (2")
7.	61-100060-000		Optical Reader UV Source Tube
8.	61-100055-002	N.A.	Tape Guide
9.	11-345154-000		Roll Pin (1/8 x 1/2) - 2 Required
10.	N.A.		Pivot Arm
11.	61-100055-004		Rubber Wheel & Hub Assembly
12.	11-106504-001		Shoulder Bolt (1")
13.	11-900070-000		Transparent Tape (1")
14.	11-023576-001	N.A.	Self Tapping Screw
15.	61-100055-020	N.A.	Track Assembly
16.	11-001178-001		Screw (1/4-20 x 1/2)
17.	11-345418-001		Roll Pin (1/4 x 1-3/4")
18.	11-005063-000	N.A.	Screw (#8-32)
19.	N.A.		Anchor Post Assembly
20.	11-345420-001		Roll Pin (1/4 x 2")
21.	11-125411-001	N.A.	Acorn Nut
22.	61-100055-013	N.A.	End Plate (left-hand)
23.	61-100055-016		Foot Pad - Small
24.	61-100055-017	N.A.	End Plate (right-hand)
25.	11-125100-001		Hex Nut (1/4-20)
26.	61-100055-001	N.A.	Foot Pad - Large
27.	61-100057-000		Label Tape (White)
28.	61-100060-000		Optical Reader UV Source Tube

*N.A. = No Longer Available*

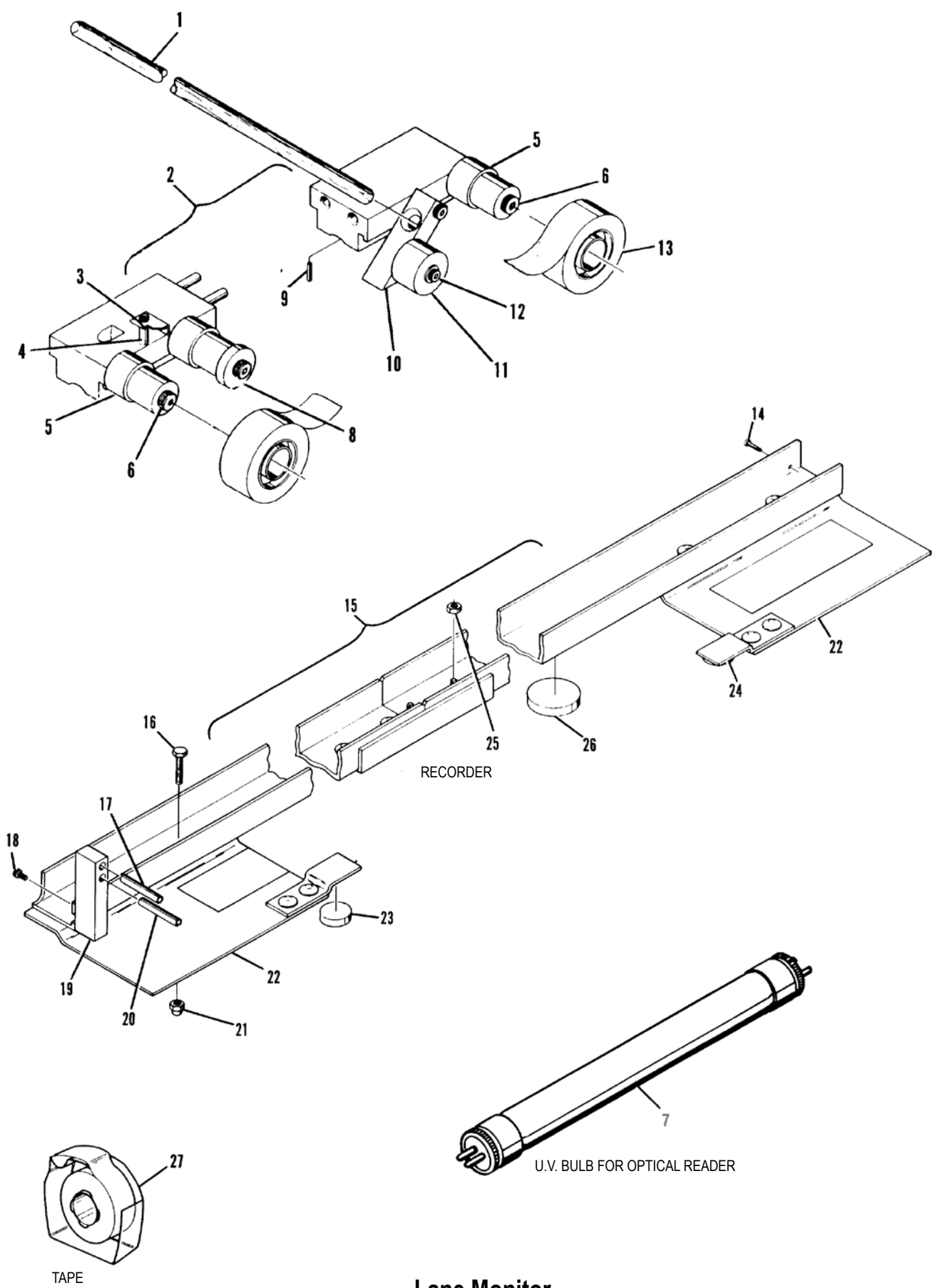

**Lane Monitor**

Index			Index		
No.	Part No.	Description	No.	Part No.	Description
		LOCKER DOOR	19.	54-100204-010	N.A. Rail Assembly (Astro 2 or "2000" Brown)
1.	N.A.	Gray Spatter - Astroline	20.	N.A.	Nameplate - Astroline
	N.A.	Gray Smooth - Astroline		N.A.	Nameplate - Astro 2
	N.A.	Off White - Astro 2		54-100415-000	N.A. Nameplate - "2000"
	54-100165-022	N.A. White Spatter - "2000"	21.	N.A.	Ferrule
2.	54-100163-000	N.A. Rubber Bumper	22.	10-193017-000	N.A. Special Washer
3.	11-012057-001	Sems C.R. Pan Hd. Machine	23.	54-100209-000	N.A. C.R. Flat Hd. Machine Screw (5/16-18 x 3/4")
		Screw (#8-32 x 5/16")	24.	N.A.	Upper Hinge Leaf
4.	54-100413-000	N.A. Lock Plate (Key Locks Only)	25.	N.A.	One Way Rd. Hd. Machine Screw (1/4-20 x 5/8")
5.	54-100164-001	N.A. Locker Number (Black on through	26.	11-176000-001	Keps Nut (1/4-20)
	54-100164-050	N.A. Denote Number Desired	27.	11-190010-001	Flat Washer (1/4)
6.	*54-100144-000	Lock w/2 Keys (Y-59)	28.	54-100467-000	N.A. Lock Plate (Combination Locks Only)
	54-100144-002	S.O. Individual Key (Y-59)		53-400235-000	N.A.
	54-100145-000	Master Key (Y-59)	29.	54-100472-000	Combination Lock
	54-100173-000	Lock w/2 Keys (LCA)		54-100472-004	Master Key
	54-100173-003	Individual Key (LCA)	30.	54-100470-000	N.A. Lock Retainer Bracket
	54-100173-004	Master Key (LCA)	31.	11-012058-000	Sems C.R. Pan Hd. MachineScrew (#8-32 x 3/8")
7.	N.A.	Slt'd. T. Hd. Machine Screw (#10-24 x 1-1/4")	32.	54-100468-000	Lock Plate Bumper
8.	N.A.	Locker Base (Astroline Gray)	33.	54-100473-001	N.A. Locker Number (White on Black) - Last 3 Digits
	54-860198-020	N.A. Locker Base (Astro 2 or "2000" Brown)		54-100473-027	N.A. Denote Number Desired
9.	54-100158-000	N.A. Hinge	34.	N.A.	Pop Rivet
10.	11-012578-002	N.A. C.R. Rd. Hd. Machine Screw (#10-24 x 1/2")	35.	N.A.	Lock Retainer
11.	54-100154-000	N.A. Tie Rod	36.	N.A.	Lock Assembly
12.	11-125004-001	Hex Nut (#10-24)	37.	11-640079-000	N.A. Master Key (Screw Type)
13.	11-199003-001	Internal Tooth Lockwasher(#10)	38.	N.A.	Master Key Holder
14.	11-013076-001	N.A. Slt'd. Pan Hd. Machine Screw (#10-24 x 3/8")	39.	N.A.	Lower Hinge Leaf
15.	N.A.	Number Plate (Specify Number)	40.	N.A.	Spacer Angle
16.	N.A.	Escutcheon Pin (#16 x 1/2")	41.	N.A.	Slt'd. Pan Hd. Machine Screw (#10-24 x 7/8")
17.	54-100210-000	N.A. Metal Glide	42.	11-190006-001	Flat Washer (#10)
18.	N.A.	End Panel Assy. (Gray)	43.	10-386241-000	N.A. Spacer (1/4 x 3/16)
	N.A.	End Panel Assy. (Astroline White)			
	N.A.	End Panel Assy. ("2000" White)			

N.A. = No Longer Available  
S.O. = Special Order  
R.O. = Replacement Option

\* To order replacement Individual Keys (54-100144-002 or 54-100173-003) place your order with:

Brunswick Corporation  
Attn: Order Department  
525 W. Laketon Avenue  
Muskegon, MI 49443

You must specify the Lock Series (Y-59 or LCA) noting key number and locker number needed. Allow four to six weeks for delivery. Individual cut keys are made per order and NO cut keys may be returned for credit.

Orders for Master Keys (54-100145-000, 54-100173-004, or 54-100472-004) must be signed by the proprietor or manager. All requests without proper authorization will be returned. Send your requests to the address at left.

Our 4600 and 5500 Series Lockers were furnished with Eagle Locks. For replacement, order our present locks (54-100144-000 or 54-100173-000).

## Bowling Ball Locker (B2000) & Freestanding Ball Rack

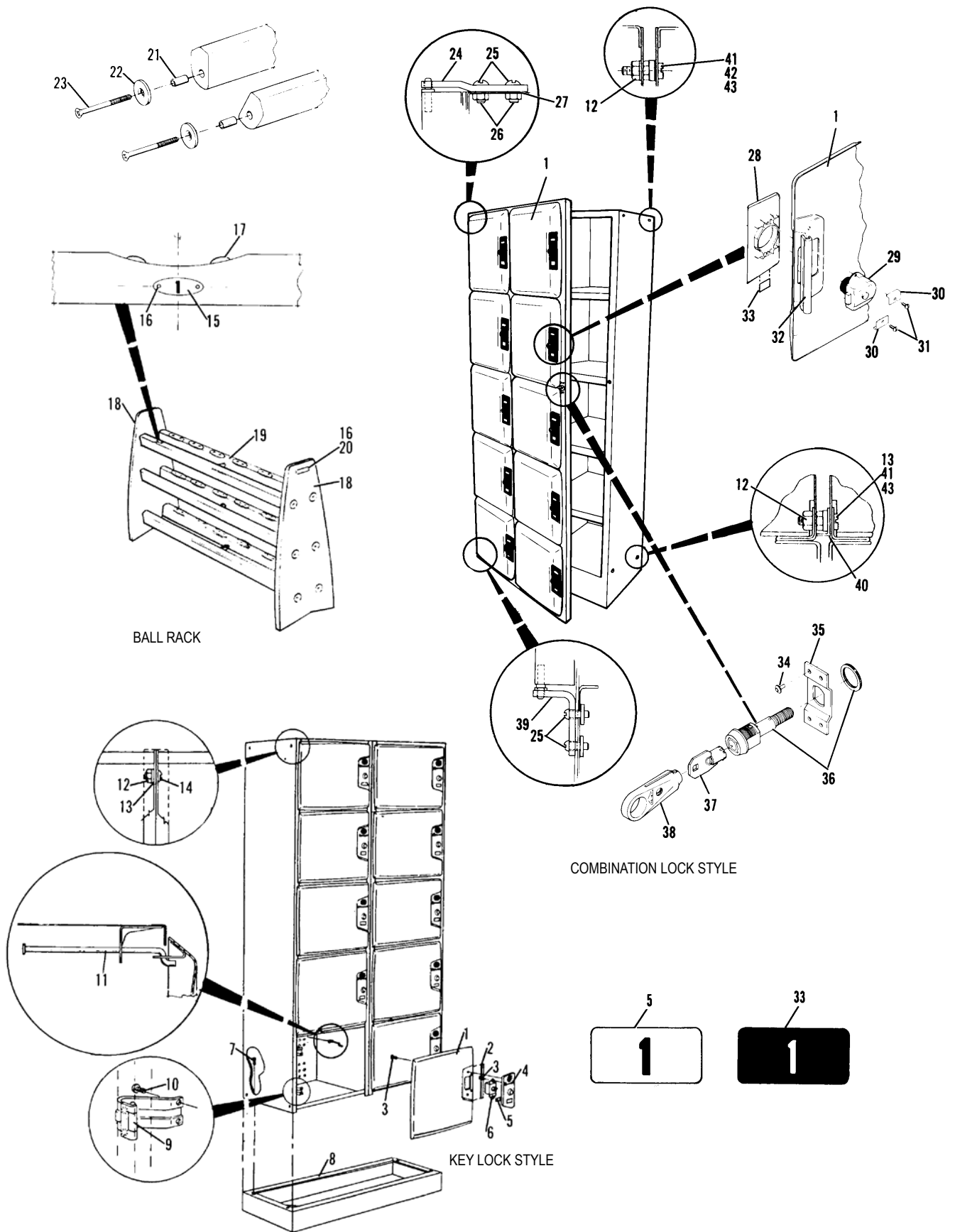

# Bowling Ball Locker (B2000) & Freestanding Ball Rack

**Index**

<b>No.</b>	<b>Part No.</b>		<b>Description</b>
1.	11-013098-001	N.A.	Slted. Pan Hd. Machine Screw (#10-32 x 5/8")
2.	11-198003-001		External Tooth Lockwasher (#10)
3.	11-001193-001		Hex Hd. Screw (1/4-20 x 2-1/4")
4.	11-001182-001		Hex Hd. Machine Screw (1/4-20 x 3/4")
5.	N.A.		Right Side Plate
6.	61-100061-002	N.A.	Duster Base Mounting Assembly
7.	61-100061-003	N.A.	Tapered Duster Roller
8.	61-100061-004	N.A.	Duster Cloth Drive Tube Assembly
9.	61-100061-005	N.A.	Idler Support
10.	61-100061-006	N.A.	Idler Spring
11.	61-100061-007	N.A.	Cloth Idler Support
12.	11-170007-001		Locknut (1/-20))
13.	61-100061-008	N.A.	Handle Assembly
14.	61-100061-009	N.A.	Crutch Tip (1" Black)
15.	61-100061-010	N.A.	Roll Pin (1/8 x 1-3/8)
16.	61-100061-011	N.A.	Drive Shaft
17.	61-100061-012	N.A.	Bushing (7/8" O.D.)
18.	61-100061-013	N.A.	Stop Pin
19.	61-100061-014	N.A.	Drive Clutch Assembly
20.	11-170014-001		Locknut (7/16-20)
21.	61-100061-015	N.A.	Drive Clutch Pedal
22.	11-013020-001		Slted. Pan Hd. Machine Screw (#6-32 x1/4")
23.	61-100061-016	N.A.	Spring
24.	11-170011-001		Locknut (3/8-16)
25.	61-100061-017	N.A.	Type A Washer (3/8)
26.	61-100061-018	N.A.	Left Side Plate
27.	11-195014-001		Lockwasher (1/4)
28.	11-125007-001		Hex Nut (1/4-20)
29.	61-100061-019	N.A.	Leather Clutch
30.	61-100061-020	N.A.	Drag Clutch Shaft
31.	61-860168-000		Duster Refills (Pkg. of 3)
32.	61-100061-021	N.A.	Frame Assembly
33.	61-100061-022	N.A.	Prong Cotter Pin (1/8 x 3/4)
34.	61-100061-023	N.A.	Clevis Pin (3/8 x 2-5/8)

*N.A. = No Longer Available*

**Lane Duster**

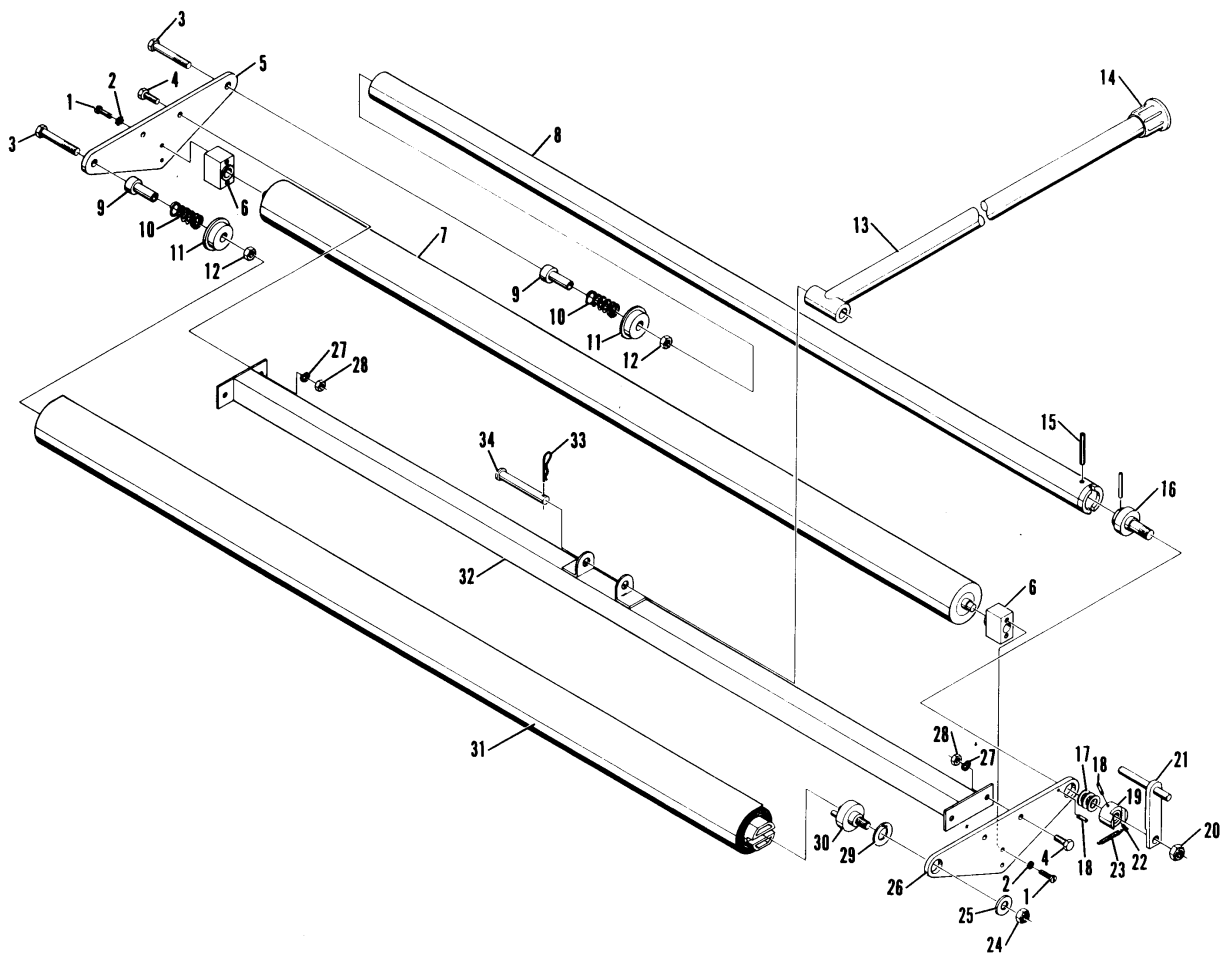

Lane Duster

**Index**

<b>No.</b>	<b>Part No.</b>		<b>Description</b>
1.	N.A.		Wood Handle Assembly - Complete
	61-860158-001	R.O.	Wood Handle Assembly
2.	31-086087-000	N.A.	Drive Tube Assembly
3.	N.A.		Spacer Pipe
4.	N.A.		Drive Plate and Shaft Assembly
5.	31-086077-000	N.A.	Torsion Spring
6.	15-650213-000	N.A.	Ratchet Wrench (7/16)
7.	31-086076-000	N.A.	Locking Screw
8.	15-600863-000	N.A.	Self Tapping Sltd. B. Hd. Screw (#10 x 3/8")
9.	31-086093-000	N.A.	Hand Knob
10.	11-190014-001		Flat Washer (3/8)
11.	31-086299-000	N.A.	L.H. End Casting Assembly
12.	N.A.		Spreader Pipe Assembly
13.	11-191010-001		Flat Washer (1/4)
14.	31-086068-000	N.A.	R.H. End Casting Assembly
15.	11-195014-001		Lockwasher (1/4)
16.	11-024288-001		C.R. T. Hd. Machine Screw (1/4-20 x 5/8")
17.	N.A.		Ratchet Wrench w/Spring
18.	52-100198-000	N.A.	Core and Plug Assembly
19.	11-607011-000	N.A.	Sleeve Cap (1" x 1")
20.	N.A.		Upper Handle
21.	14-300040-000	N.A.	Quick Release Pin
22.	N.A.		Lower Handle
23.	14-300055-000	N.A.	Yoke
24.	11-335053-001	N.A.	Cotter Key
25.	N.A.		Shaft
26.	52-100395-000	N.A.	Spreader Cushion
27.	52-100401-000	N.A.	Polyethelene Cover
28.	N.A.		Retainer Bar
29.	N.A.		C.R. Pan Hd. Machine Screw (#8-32 x 1")
30.	11-125003-001		Hex Nut (#8-32)

*N.A. = No Longer Available*

*R.O. = Replacement Option*



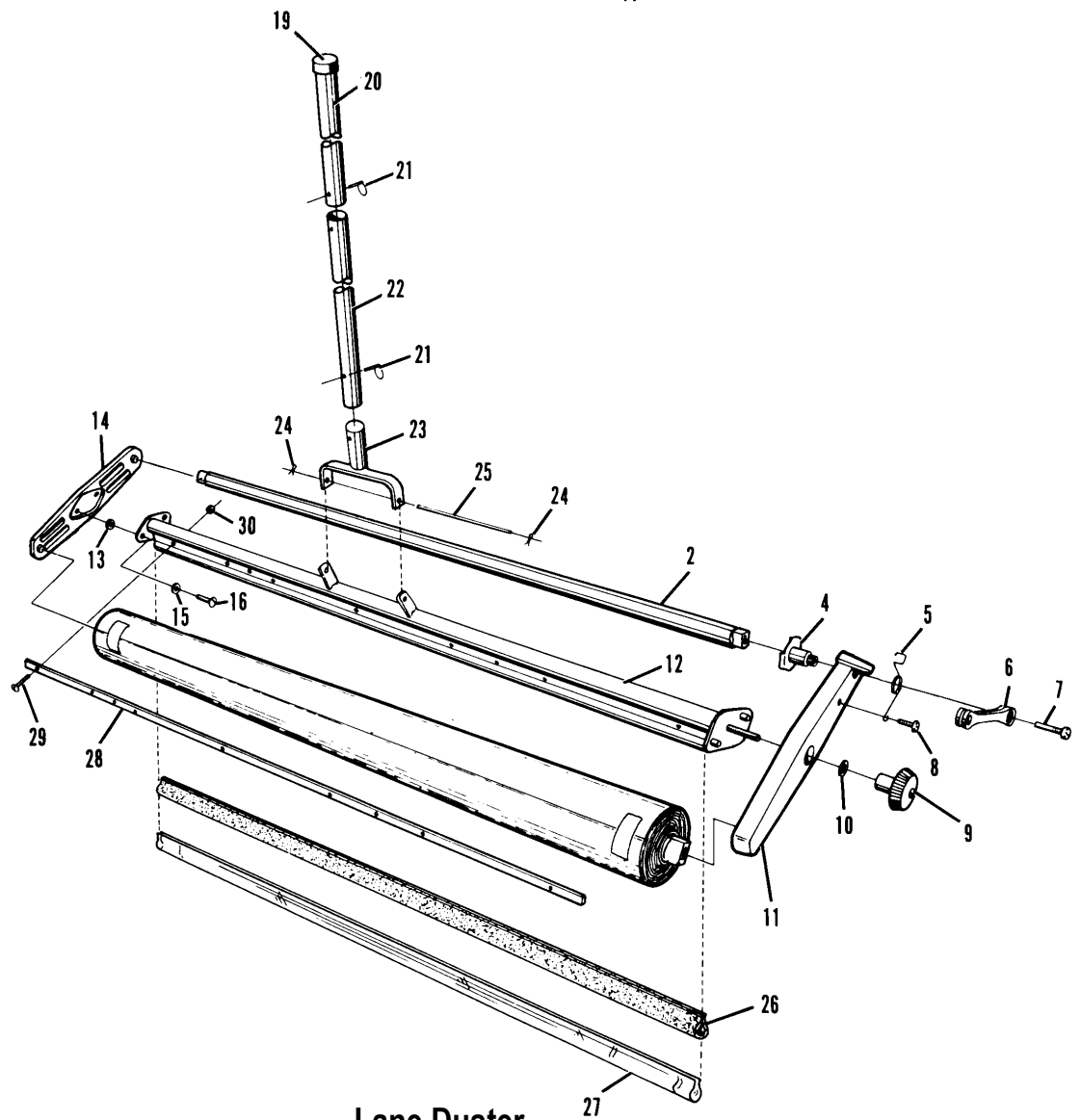
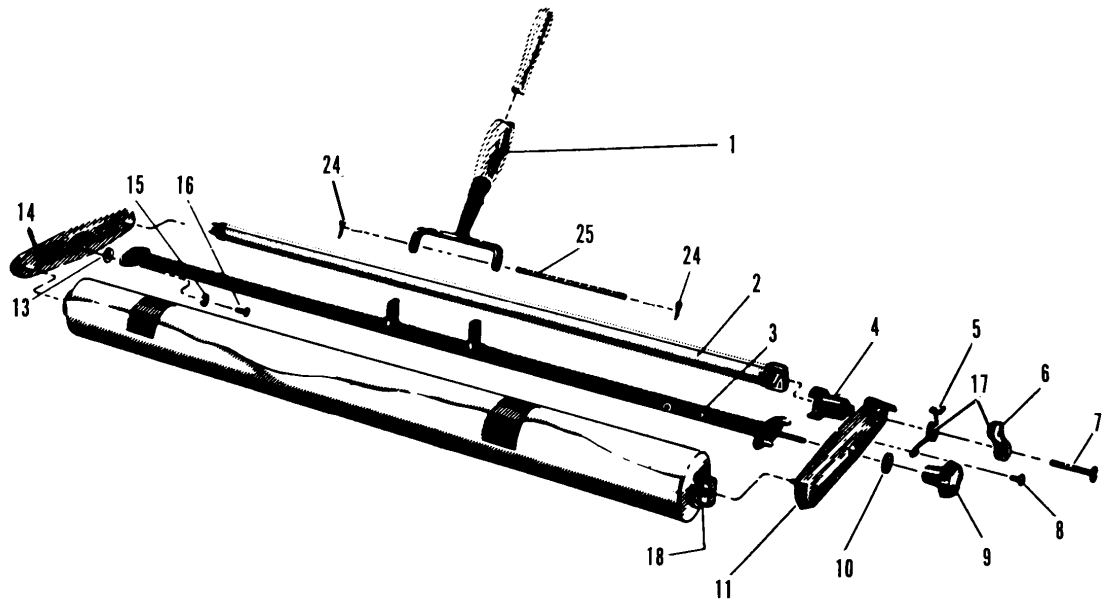

Lane Duster

Index			Index		
No.	Part No.	Description	No.	Part No.	Description
1.	N.A.	Hex Socket Hd. Stripper Bolt (1/4-20 x 1")	33.	N.A.	Wood Bumper
2.	11-190508-001	Flat Washer	34.	N.A.	Slted. Rd. Hd. Machine Screw (#8-32 x 1-1/4")
3.	11-190523-001	N.A. Flat Washer	35.	11-190004-001	Flat Washer (#8)
4.	11-176000-001	Keps Nut (1/4-20)	36.	N.A.	Weight Bar (5#)
5.	90-200114-000	Urethane Roller Assembly		N.A.	Weight Bar (8#)
6.	N.A.	Guide Roller Assembly		14-300046-004	N.A. Weight Bar (10#)
7.	N.A.	Bracket	37.	14-300022-000	N.A. Front Support
8.	11-125007-001	Hex Nut (1/4-20)	38.	14-300024-000	N.A. Foam Pad
9.	11-190010-001	Flat Washer (1/4)	39.	14-300021-000	N.A. Channel
10.	11-012391-001	N.A. C.R. Pan Hd. Machine Screw (1/4-20 x 1-3/4")	40.	11-001180-001	Hex Hd. Cap Screw (1/4 x 5/8")
	12-502345-000	R.O. Bumper Screw	41.	14-300011-002	R.H. Plastic Wing
11.	14-300029-003	Angle Bracket and Pin Assembly		14-300011-003	L.H. Plastic Wing
12.	14-300040-000	N.A. Quick Release Pin	42.	14-300025-000	N.A. Applicator Board
13.	11-607011-000	N.A. Sleeve Cap	43.	N.A.	Slted. Rd. Hd. Machine Screw (#6-32 x 1/2")
14.	N.A.	Upper Handle Assembly	44.	11-190002-001	Flat Washer (#6)
	N.A.	Upper Handle Only	45.	11-125001-001	Hex Nut (#6-32)
15.	N.A.	Lower Handle Assembly	46.	N.A.	Squeegee
16.	N.A.	Lower Handle Only	47.	N.A.	Wet Film Thickness Gauge
17.	11-345314-001	Roll Pin	48.	N.A.	Spatula
18.	N.A.	Handle Plug	49.	N.A.	Thermometer
19.	N.A.	Yoke	50.	N.A.	End Clamp
20.	11-530021-001	Retaining Ring	51.	N.A.	L.H. End Bracket
21.	11-001178-001	Hex Hd. Cap Screw (1/4-20 x 1/2")	52.	N.A.	Lower Yoke
22.	11-195014-001	Lockwasher (1/4)	53.	14-300055-000	N.A. Handle Yoke
23.	N.A.	Frame and Arm Assy.	54.	11-176006-001	Keps Nut (#10-24)
24.	N.A.	C.R. Flat Hd. Machine Screw (#10-24 x 5/8")	55.	N.A.	Shaft
25.	11-190012-001	Flat Washer (5/16)	56.	11-335053-001	N.A. Cotter Key
26.	11-534512-000	N.A. Grip Ring	57.	N.A.	Rear Clamp Strip
27.	14-300029-002	N.A. Angle Bracket and Pin Assembly	58.	N.A.	Frame Channel
28.	14-300030-000	N.A. Glide	59.	N.A.	Wing Nut (#10-24)
29.	11-014146-001	N.A. C.R. Flat Hd. Machine Screw (1/4-20 x 5/8")	60.	N.A.	R.H. End Bracket
30.	N.A.	Mounting Plate	61.	11-014082-001	N.A. C.R. Flat Hd. Machine Screw (#10-24 x 3/8")
31.	11-125003-001	Hex Nut (#8-32)	62.	11-014091-004	N.A. C.R. Flat Hd. Machine Screw (#10-24 X 1-1/8")
32.	11-195008-001	Lockwasher (#8)	63.	N.A.	Applicator Pad
			64.	N.A.	Front Clamp Strip

N.A. = No Longer Available

R.O. = Replacement Option

## Finish Applicator

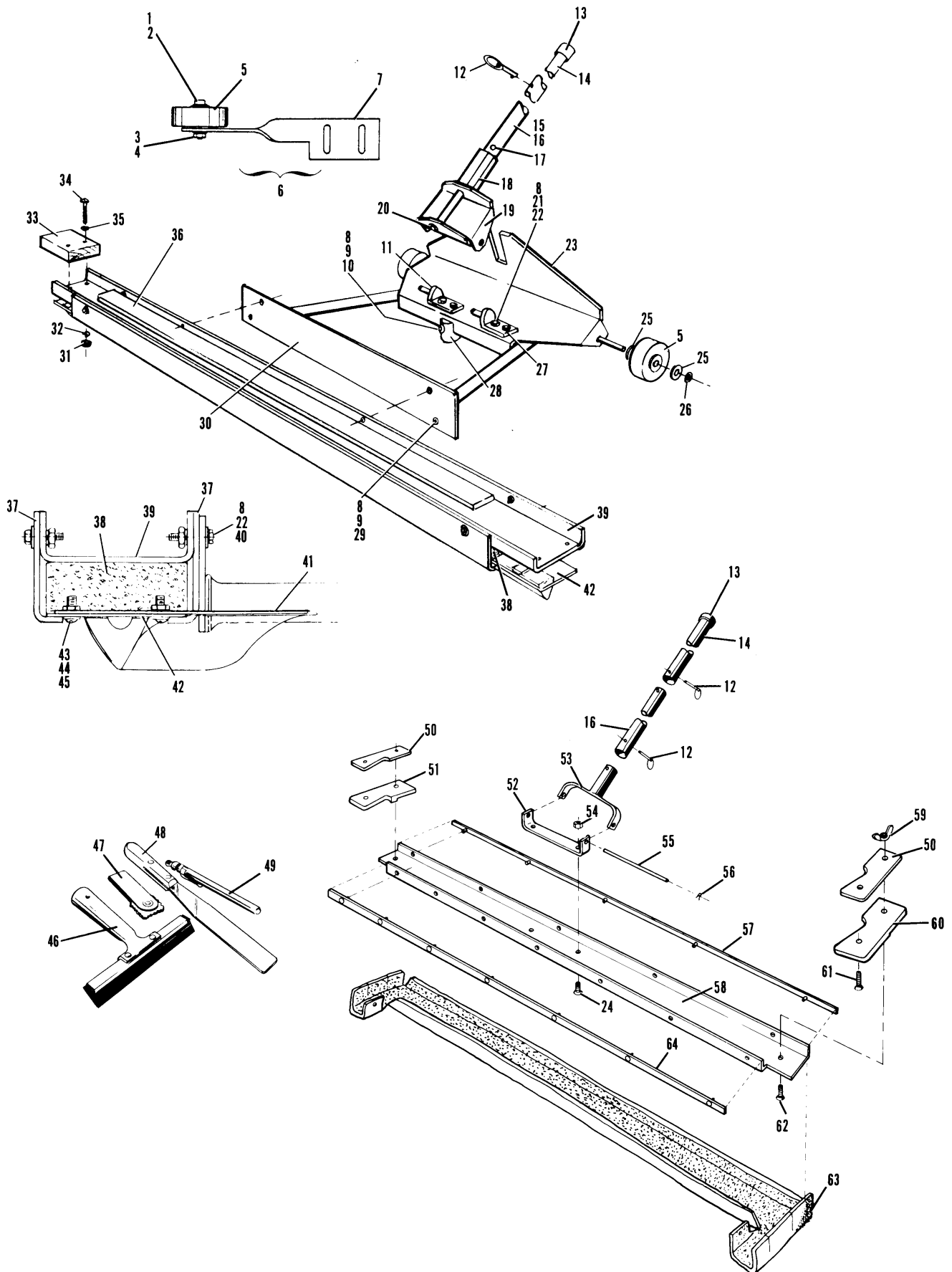

Finish Applicator

**Index**

<b>No.</b>	<b>Part No.</b>		<b>Description</b>
1.	11-125004-002	N.A.	Hex Nut (#10-24)
2.	11-199003-002	N.A.	Lockwasher (#10)
3.	11-013076-002	N.A.	Pan Hd. Screw (#10-24 x 3/8")
4.	53-400235-000	N.A.	Lock Plate (Gray)
	54-100467-000	N.A.	Lock Plate (Chrome)
	53-400235-000	N.A.	Lock Plate Combination
5.	*53-400236-001	N.A.	Locker Numbers (#1-30)
	to		
	*53-400236-050	N.A.	Locker Numbers (#1471-1500)
6.	11-012058-000		Pan Hd. Screw (#8-32 x 3/8)
7.	54-100468-000	N.A.	Lock Plate Bumper
8.	54-100472-000		Combination Lock
	54-860477-000	N.A.	Combination Lock Key (Pkg. of 10)
	54-100427-004	N.A.	Master Key
9.	54-100470-000	N.A.	Lock Retainer Brackets
10.	53-400234-000	N.A.	Locker Door (w/o Lock)
11.	11-021578-002	N.A.	Pan Head C.R. Screw (#10-24 x 1/2")

*N.A. = No Longer Available*

*R.O. = Replacment Option*

\* Last three digits denote number desired. Thirty numbers to a package.  
All locker numbers are Frameworx Gray.

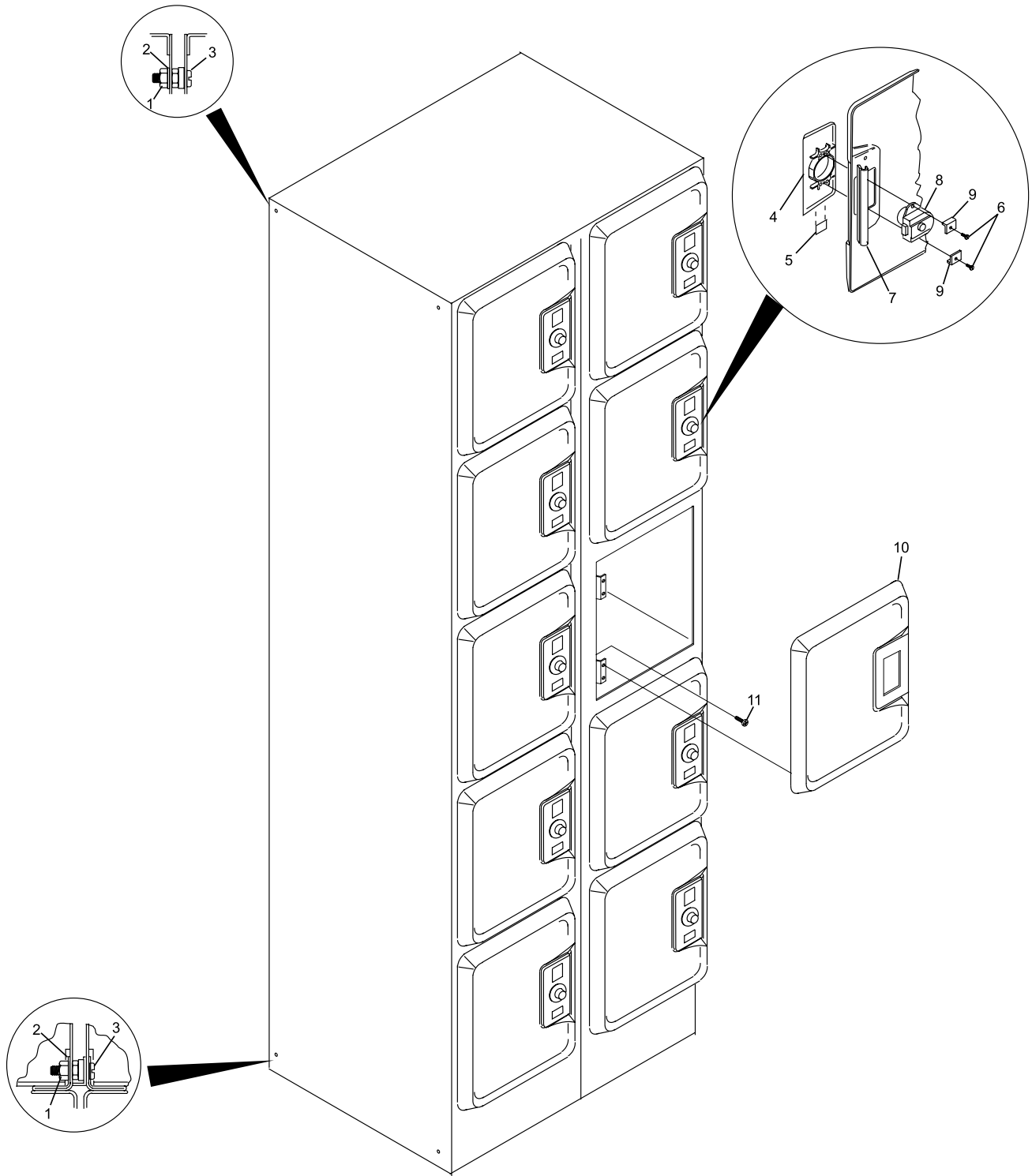

Frameworkx Lockers

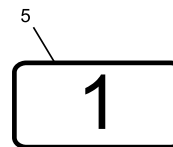

**Index**

<b>No.</b>	<b>Part No.</b>	<b>Description</b>
1.	84-200299-000	Cosmetic Cover - Pkg of 20
2.	53-860326-230	Pkg. Transformer Kit w/IEC Connector, Bracket and Hardware 100VAC, 50 Hz (for Japanese market)
	53-860628-115	Pkg. Transformer Kit w/Bracket and Hardware
	53-860629-230	R.O. Transformer Pkg. - 230VAC, 50 Hz w/Power Cord
	53-860327-115	N.A. Transformer - 115VAC, 60 Hz
	53-860628-115	R.O. Transformer Pkg. - 115VAC, 60 Hz w/Power Cord
	53-860326-100	Transformer - 100VAC, 50 Hz
3.	84-200292-000	N.A. Address Decoder Module
	84-200847-000	R.O. Address Decoder Module Assembly
4.	84-200330-400	N.A. Lightworx Controller - Complete
5.	84-860612-000	N.A. Keypad Only
6.	84-860607-000	N.A. Light Module PCB
7.	84-200295-000	N.A. Light Module Assembly - Complete
	84-200760-000	N.A. Light Module Assembly - Complete
	84-200845-000	R.O. Light Module Assembly, LT. Grey - Complete
8.	84-200353-000	N.A. Light Module Assembly - Scorer Pedestal
9.	57-300943-000	N.A. Splitter Assembly - Scorer Pedestal
	57-861953-000	R.O. Splitter Assembly - Scorer Pedestal
10.	84-200224-301	N.A. PKG. 6 Clear Division Capping
	84-860736-301	R.O. PKG. 6 Clear Division Capping
11.	84-200241-000	Lower Division Capping - Gray (9' 9")

*N.A. = No Longer Available*

*R.O. = Replacement Option*

## Lightworx System

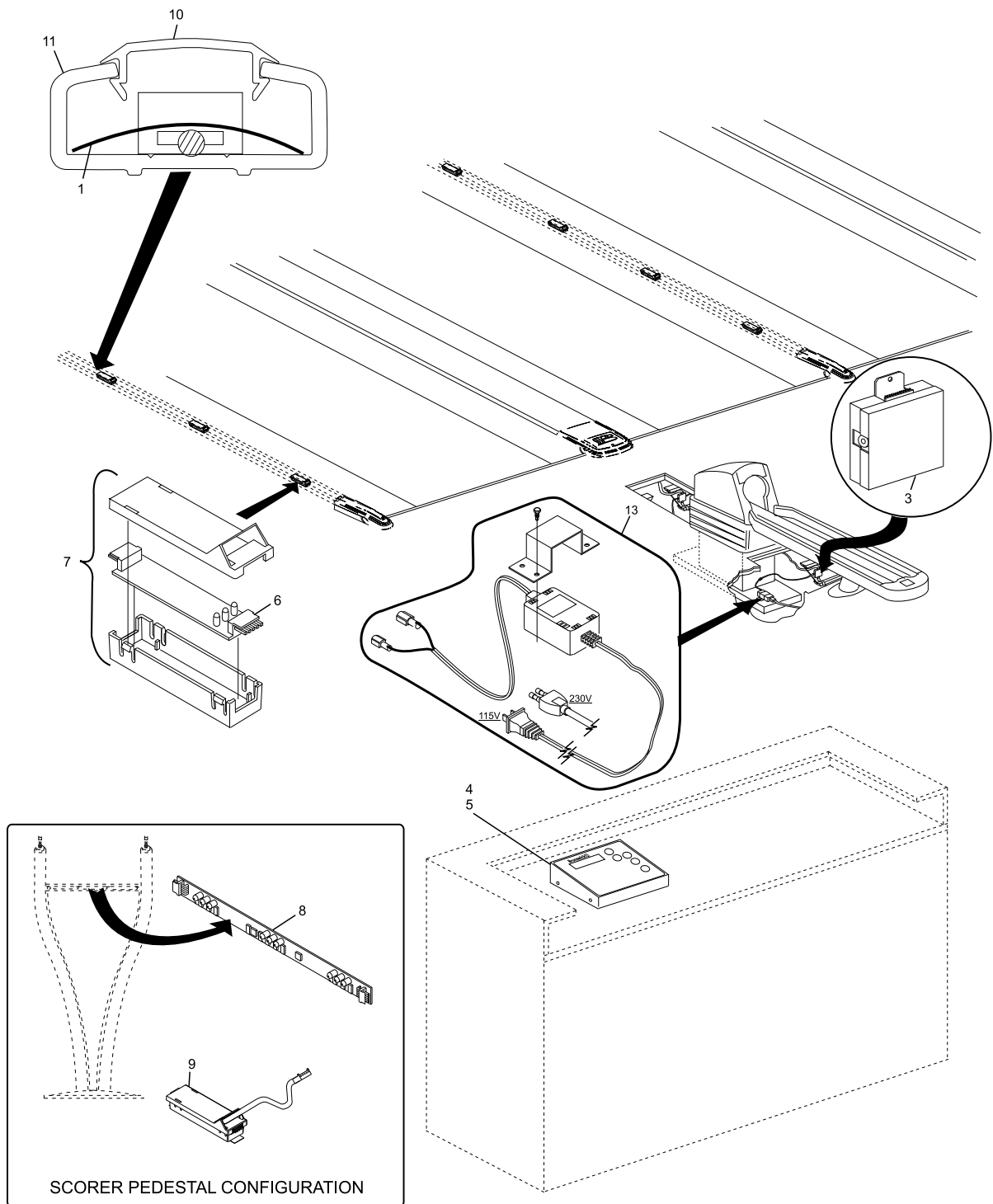

**Lightworx System**

**Index**

<b>No.</b>	<b>Part No.</b>		<b>Description</b>
1.	84-200287-000		Light Module to Light Module Cable
2.	84-200298-000		Address Decoder Module to Light Module Cable (20')
3.	84-200288-000		Address Decoder Module to Address Decoder Module Cable (16')
4.	84-200289-000		Control Module Interface Cable (300')
5.	11-697219-000		Connector
6.	11-680326-000		Terminal
7.	11-680998-000	N.A.	Connector
8.	11-680981-000		Terminal
9.	84-200331-000	N.A.	Lightworx Controller Power Adapter Cable (10")
	17-860792-000	R.O.	Power Adapter Cable ABW Standard
10.	84-200332-000		Address Decoder Module Power Adapter Cable (1')

*N.A. = No Longer Available*

**Lightworx System Cables**



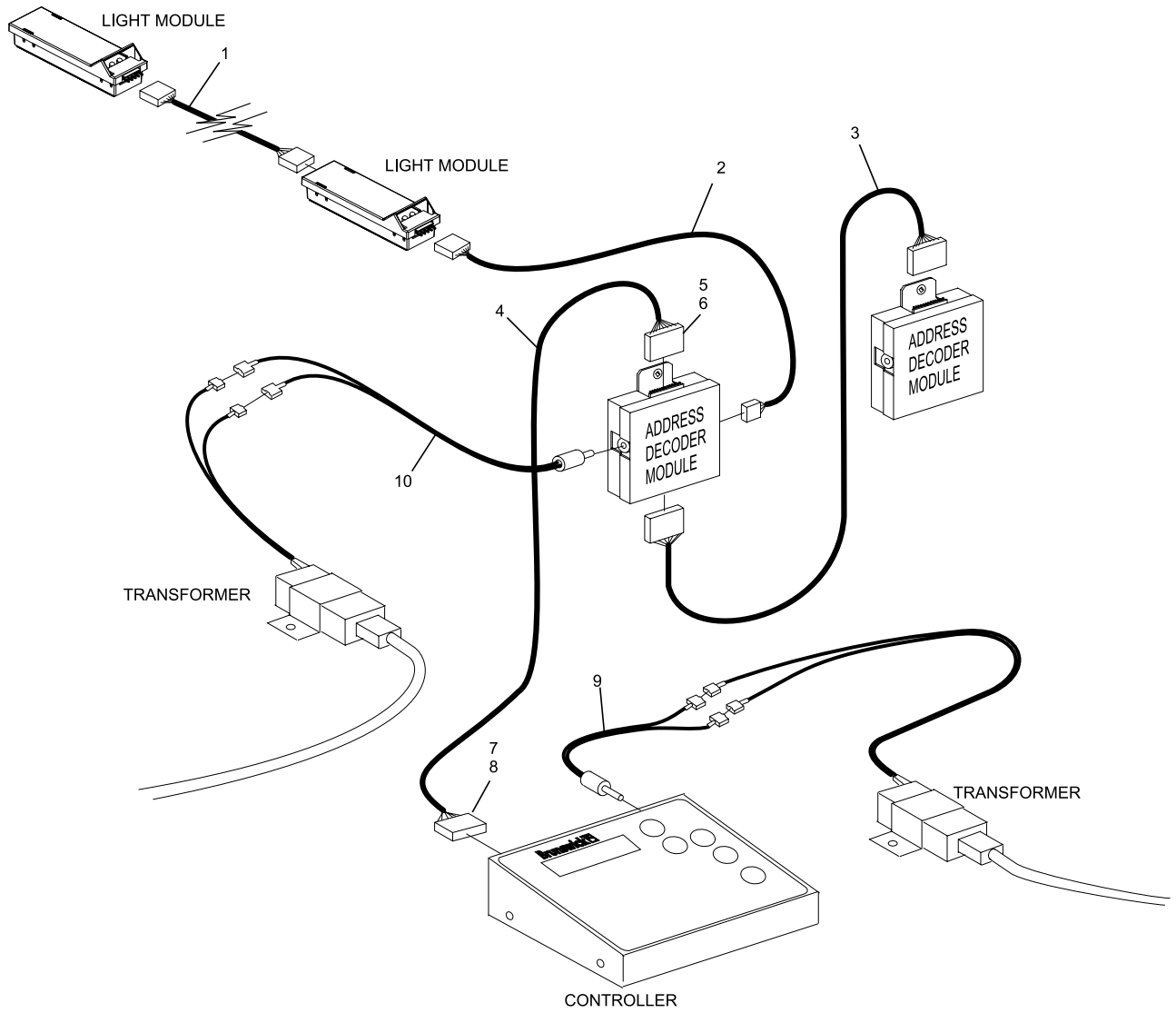

## Lightworx System Cables