

Section E

SWEEP WAGON

Index

No.	Part No.	Description
1.	47-042058-002	Sweep Wagon Frame only (uses Leaf Springs)
	N.A.	Sweep Wagon Frame w/o Leaf Springs
2.	47-041769-003	Sweep Board Only (brown for GS-10, GS-92 or GS-96)
3.	47-041721-002	Gutter Adapter
4.	47-041636-004	Protection Strip
5.	47-041750-004	Spacer
6.	47-041751-004	Protector
7.	46-040170-004	Roller
8.	99-040249-004	Plastic Roller Assembly
9.	47-041737-004	Retaining Flat Spring
10.	47-041734-004	Flat Spring
11.	47-041735-004	Flat Spring
12.	47-041736-004	Flat Spring
13.	47-041738-004	Flat Spring
14.	11-051013-001	Hex Hd. Cap Screw (10 mm x 90 mm)
15.	11-051745-001	Locknut (10 mm)
16.	11-051770-001	Lockwasher (8 mm)
17.	47-041774-004	Bracket
18.	47-041526-003	N.A. R.H. Pusher Rod
19.	47-042056-003	L.H. Pusher Rod (shown)
20.	11-052608-001	Carriage Bolt (8 mm x 150 mm)
21.	11-051792-001	Split Pin (3.2 mm x 28 mm)
22.	11-052607-001	Carriage Bolt (6 mm x 45 mm)
23.	11-052037-001	Flat Washer (6.4 mm)
24.	11-051743-001	Locknut (6 mm)
25.	11-051744-001	Locknut (8 mm)
26.	11-052006-001	Flat Washer (8.4 mm)
27.	11-051852-001	Retaining Ring (17 mm)
28.	*11-052012-001	Flat Washer (18 mm)
29.	11-051747-001	Locknut (12 mm)
30.	11-052024-001	N.A. Flat Washer (13 mm)
	47-861010-001	R.O. Flat Washer (13 mm) Pkg. of 20
31.	11-051070-001	Hex Hd. Cap Screw (12 mm x 60 mm)
32.	11-051038-001	Hex Hd. Cap Screw (8 mm x 16 mm)
33.	11-052003-001	Flat Washer (8.4 mm)
34.	11-052034-001	Flat Washer (15 mm)
	11-054103-001	Spacer Washer (16 mm)
35.	99-010103-004	Plastic Bearing
36.	47-041637-001	Sweep Wagon Assembly Complete
37.	47-042545-000	N.A. Sweep Board Decal (GS-10)
	47-044692-004	N.A. Sweep Board Decal (GS-92)
	47-044801-004	Sweep Board Decal (GS-96)
	47-045082-004	Sweep Board Decal (GS-98)
	47-045373-004	Sweep Board Decal (GS-X)
38.	47-044802-009	Sweep Board w/Felt (Brown)
	47-044927-003	Sweep Board only (Gray)
39.	*47-043772-004	Felt only
40.	46-040170-004	Roller
41.	11-052053-001	Flat Washer (17 mm)

N.A. = No Longer Available

R.O. = Replacement Option

* Not Illustrated

Sweep Wagon Assembly - with Springs

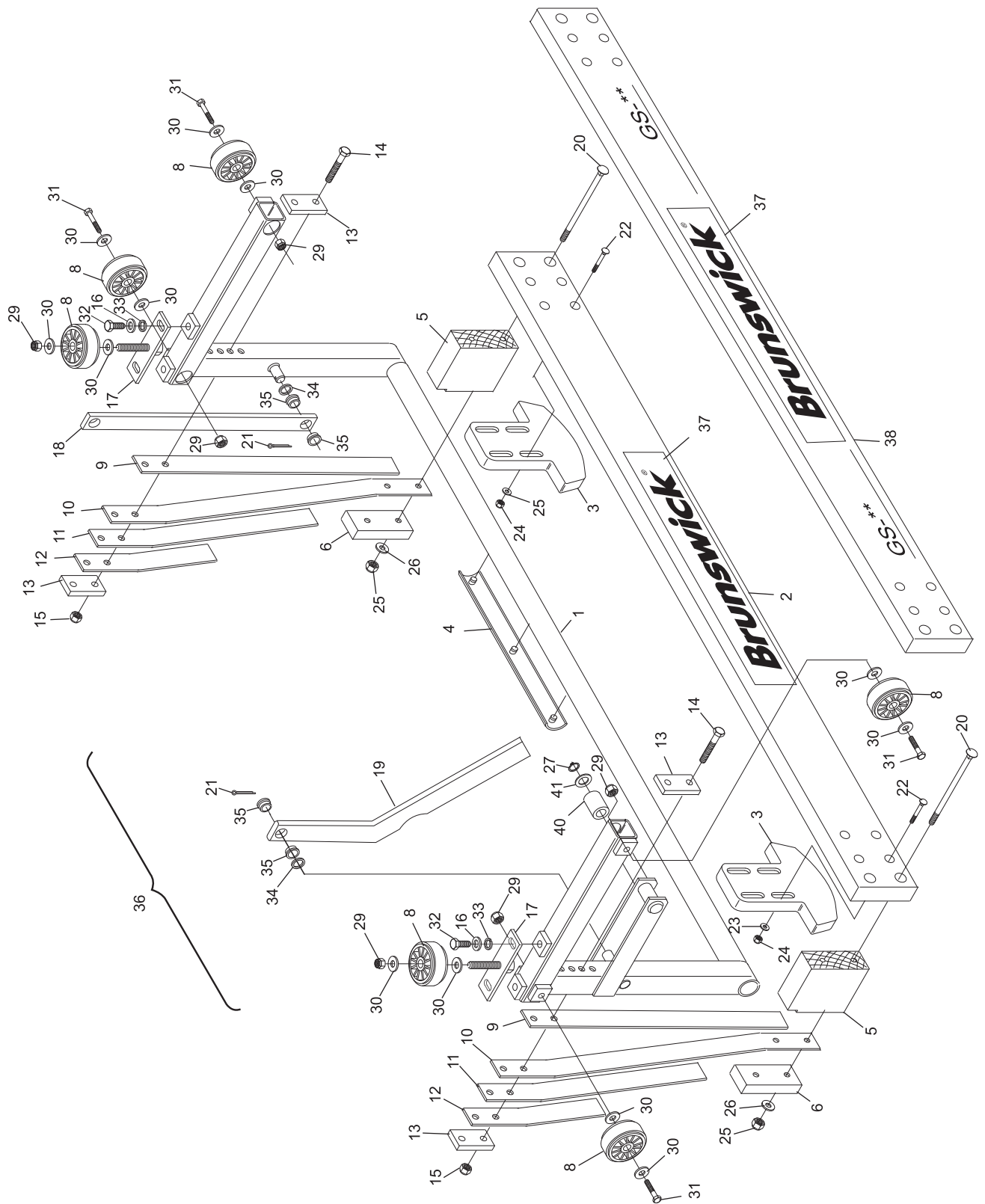

Sweep Wagon Assembly - with Springs

Index

No.	Part No.	Description
1.	47-044927-003	Sweep Board Only (gray for GS-98, or GS-X)
2.	47-041721-002	Gutter Adapter
3.	99-040249-004	Plastic Roller Assembly
4.	47-041774-004	Bracket
5.	47-041526-004	R.H. Pusher Rod
6.	47-042056-003	L.H. Pusher Rod
7.	11-051743-001	Locknut (6 mm)
8.	11-051747-001	Locknut (12 mm)
9.	11-052024-001	N.A. Flat Washer (13 mm)
	47-861010-001	R.O. Flat Washer (13 mm) Pkg of 20
10.	11-051070-001	Hex Hd. Cap Screw (12 mm x 60 mm)
11.	11-051010-001	Hex Hd. Cap Screw (8 mm x 20 mm)
12.	11-052019-001	Flat Washer (8.4 mm)
13.	47-045082-004	Sweep Board Decal (GS-98)
	47-045373-004	Sweep Board Decal (GS-X)
14.	47-044802-009	Sweep Board w/Felt (Brown)
15.	47-044979-004	Rubber Bumper
16.	11-051770-001	Lockwasher (8 mm)
17.	11-052034-001	Flat Washer (15 mm)
18.	99-010103-004	Plastic Bearing
19.	11-051869-000	Retaining Ring (15 mm)
20.	11-052614-001	Carriage Bolt (6 mm x 40 mm)
21.	11-052601-001	Carriage Bolt (8 mm x 30 mm)
22.	11-052035-001	Flat Washer (10.5 mm)
23.	11-051744-001	Locknut (8 mm)
24.	47-045010-002	Sweep Wagon (Frame only)
25.	47-044976-004	Felt only
26.	46-040170-004	Roller
27.	11-052053-001	N.A. Flat Washer (17 mm)
	47-861011-001	R.O. Flat Washer (17 mm) Pkg of 10
28.	11-051852-001	Retaining Ring (17 mm)
29.	47-044978-004	Foot Cap - see index 33
30.	47-045013-009	S.O. Sweep Wagon - Complete
31.	11-054103-001	N.A. Shim Washer (16 mm)
	47-861029-001	R.O. Shim Washer (16 mm x 28 mm x .5 mm) Pkg. of 10
32.	11-051786-001	Cotter Pin
33.	*47-862011-000	GS Sweep Foot Cap Upgrade Kit (includes 25 fastening pins, drill bit and instructions). Kit does not include foot caps and should be ordered as needed.

N.A. = No Longer Available

S.O. = Special Order

** Item Not Shown*

Sweep Wagon Assembly - without Springs (Machine Series 424 and Above)

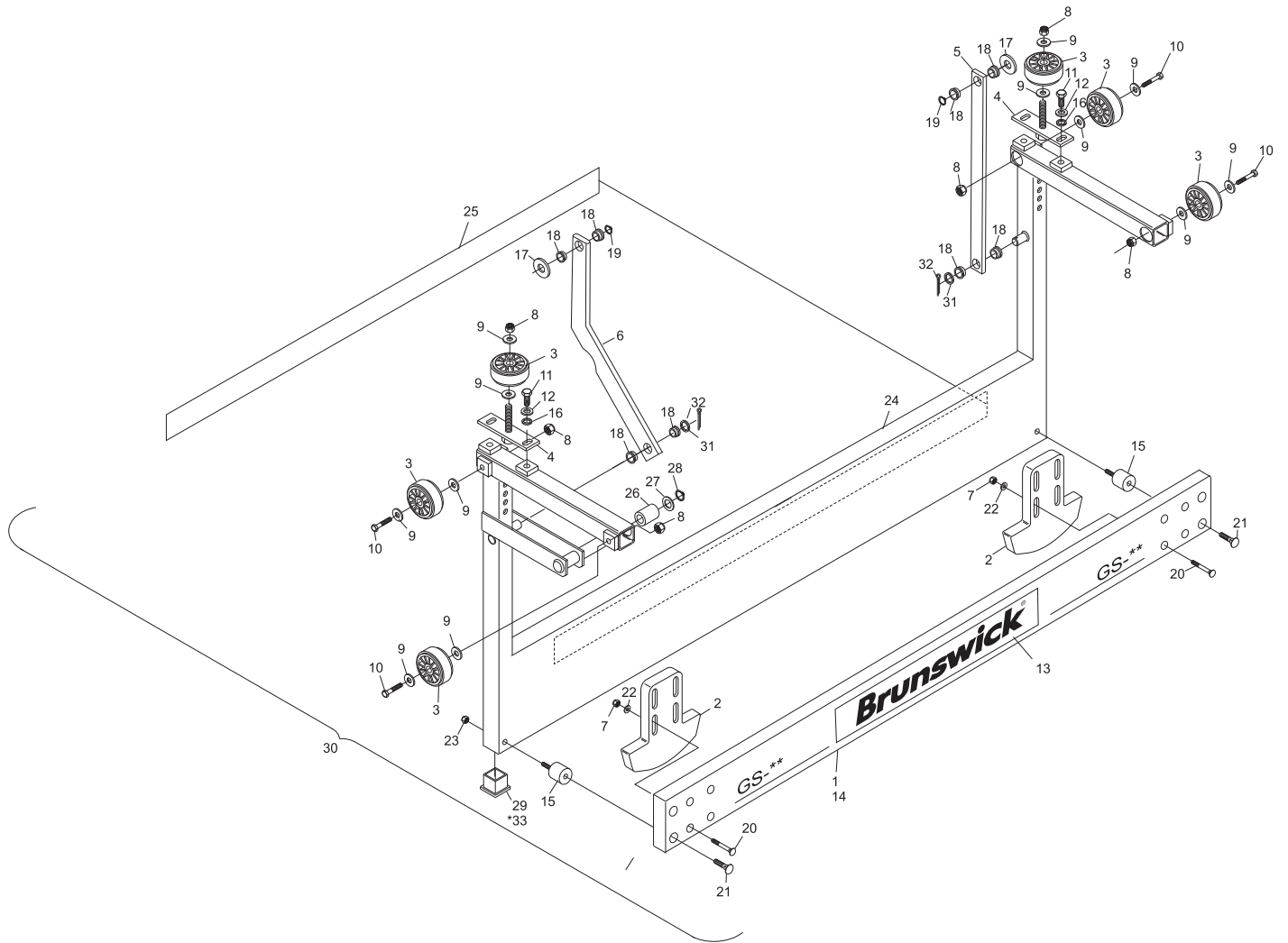

**Sweep Wagon Assembly - without Springs
(Machine Series 424 and Above)**

Index

No.	Part No.	Description
1.	**47-045566-009	Sweep Release/Holder Complete (for Tower Down machine)
2.	11-051509-001	Socket Hd. Cap Screw (6 mm x 12 mm)
3.	11-051518-001	Socket Hd. Cap Screw (10 mm x 40 mm)
4.	47-041786-003	Yoke
5.	11-601005-000	Chain - Master Link Included (21 Link -Tower Up Machine)
	47-045487-004	Chain - Master Link Included (25 Link -Tower Down Machine)
6.	11-051743-001	Locknut (6 mm)
7.	11-051745-001	Locknut (10 mm)
8.	99-060219-004	Solenoid Assembly Complete (red box)
9.	99-060133-004	Plunger Only
10.	11-051063-001	N.A. Hex Hd. Cap Screw (5 mm x 65 mm)
	47-861002-001	R.O. Hex Hd. Cap Screw (5 mm x 65 mm) Pkg. of 20
11.	11-052039-001	Flat Washer (5.3 mm)
12.	N.A.	Plug Only
13.	11-051742-001	Locknut (5 mm)
14.	47-041793-001	Arm
15.	47-041792-004	Tension Spring
16.	47-041787-003	Spring Holder
17.	47-041976-004	Tie Plate
18.	11-053480-001	Speed Nut (10 mm)
19.	N.A.	Flat Washer (5.3 mm)
20.	11-051791-001	Split Pin (1.6 mm x 10 mm)
21.	47-045140-004	Connecting Link
22.	*47-041791-004	Tension Spring
23.	47-043790-004	Plastic Tube (12/16 x 12)
24.	11-053478-001	N.A. Speed Nut (8 mm)
	47-861050-000	R.O. Speed Nut (8 mm) Pkg. of 10
25.	47-041783-003	Tipper
26.	47-041790-004	Tension Spring
27.	11-052025-001	Flat Washer (4.3 mm)
28.	47-045139-004	Connecting Link w/Starlock
29.	47-041784-004	Lever
30.	47-041788-002	Swing Lever
31.	11-430006-000	N.A. Bearing
32.	11-051038-001	Hex Hd. Cap Screw (8 mm x 16 mm)
33.	11-052003-001	Flat Washer (8.4 mm)
34.	11-054103-001	Spacer Washer (16 mm)
35.	47-040260-003	Sweep Guide Lever Pivot
36.	47-040283-003	Sweep Guide Lever
37.	*11-052024-001	N.A. Flat Washer (13 mm)
	47-861010-001	R.O. Flat Washer (13 mm) Pkg. of 10
38.	*11-051807-001	Cotter Pin (2 mm x 20 mm)
39.	*47-243030-004	N.A. Solenoid Assembly
	99-070356-004	R.O. Solenoid
40.	*11-052028-001	Flat Washer (10.5 mm)

N.A. = No Longer Available

R.O. = Replacement Option

* Not Illustrated

** When used with Tower Up pinsetter, remove 4 links as only 21 are needed

NOTE: Index No. 8 and index No. 39 do not include Index No. 9, Plunger

Sweep Release

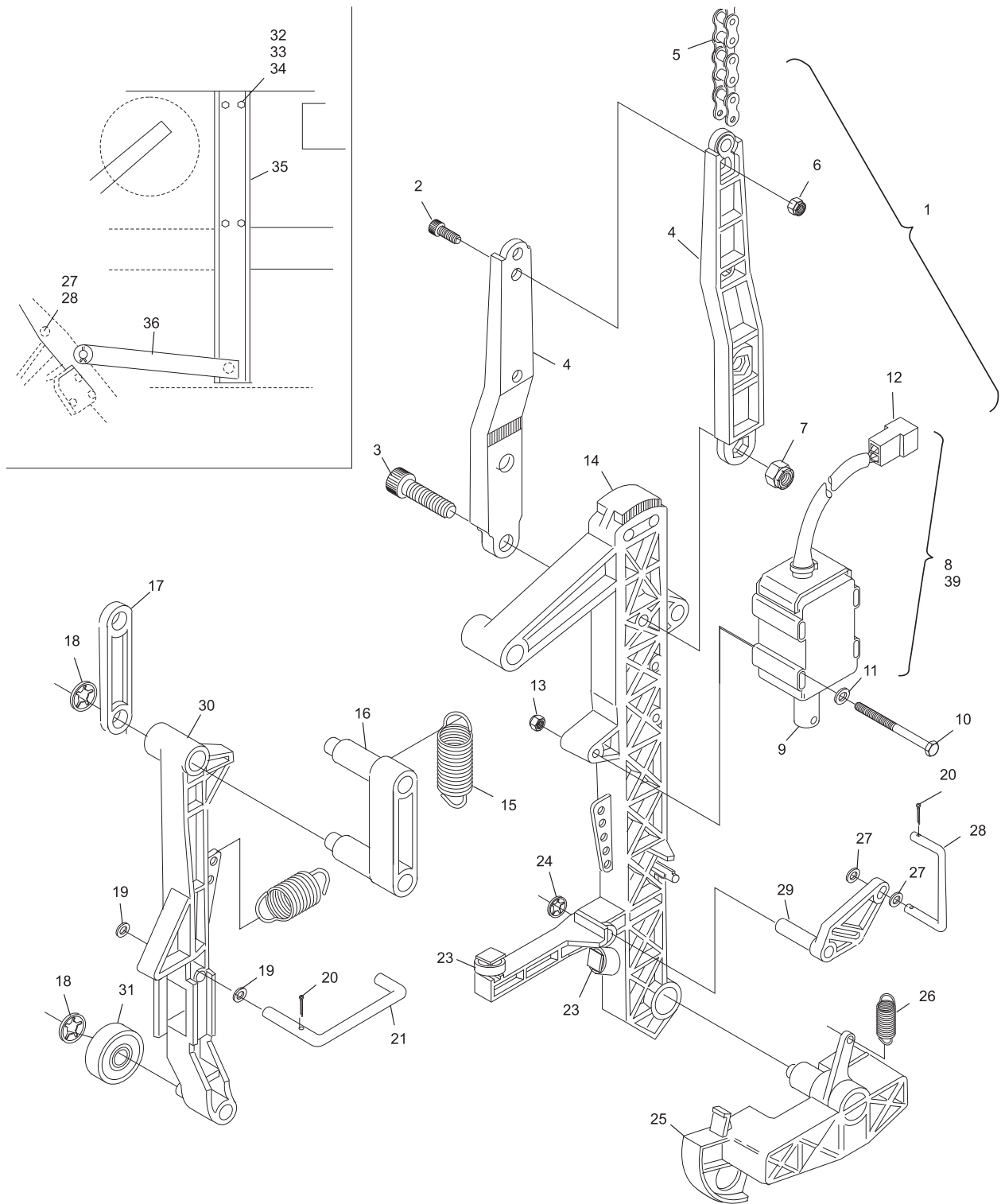

Sweep Release

Index

No.	Part No.	Description
1.	47-041814-003	Holder
2.	11-051038-001	Hex Hd. Cap Screw (8 mm x 16 mm)
3.	11-052003-001	Flat Washer (8.4 mm)
4.	11-051744-001	Locknut (8 mm)
5.	47-243027-004	Switch (silver box, consolidated and nexgen) Switch Assembly
6.	47-043698-004	Top Shaft
7.	47-041816-001	Guide Hook
8.	99-040151-004	Connector Joint
9.	11-053101-000	Set Screw (6 mm x 8 mm)
10.	11-053616-001	Stop Collar (15 mm)
11.	47-041813-004	Bushing
12.	11-053480-001	Speed Nut (10 mm)
13.	47-081654-004	Tension Spring
14.	11-051772-001	Lockwasher (12 mm)
15.	11-053154-001	Jam Nut (12 mm)
16.	99-040400-002	N.A. Sweep Attenuator Hydraulic Complete
	99-046122-000	R.O. Hydraulic Sweep Wagon Assembly
17.	47-041812-004	Bottom Shaft (130 mm)
18.	11-051787-001	Split Pin (2 mm x 25 mm)
19.	11-051703-001	Hex Nut (10 mm)
20.	11-051771-001	Lockwasher (10 mm)
21.	11-051538-001	Socket Hd. Cap Screw (10 mm x 50 mm)
22.	11-052035-001	Flat Washer (10.5 mm)
23.	47-043583-004	Spacer
24.	99-050230-004	Switch (red box)
25.	11-052206-001	Cap Screw (4 mm x 25 mm)
26.	11-051741-001	Locknut (4 mm)
27.	N.A.	Sweep Attenuator Assembly Complete

N.A. = No Longer Available

R.O. = Replacement Option

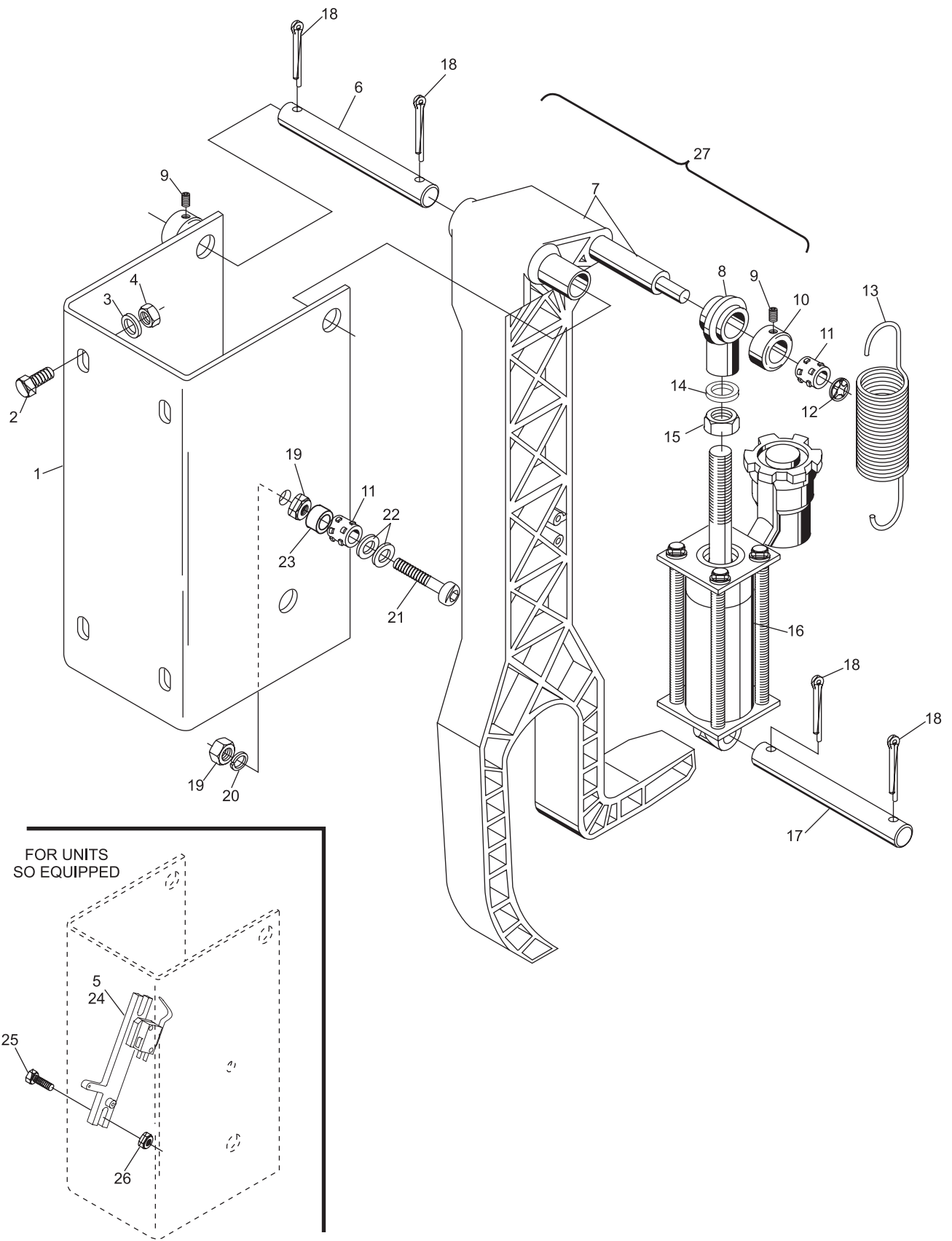

**Pre GS-X
Sweep Attenuator Assembly**

Index

No.	Part No.	Description
1.	47-045372-003	Holder Support
2.	11-051038-001	Hex Hd. Cap Screw (8 mm x 16 mm)
3.	11-052003-001	Flat Washer (8.4 mm)
4.	11-051744-001	Locknut (8 mm)
5.	47-243027-004	Switch Assembly (silver box, consolidated and nexgen)
6.	47-045551-004	Top Shaft
7.	47-041816-001	Guide Hook
8.	99-040151-004	Connector Joint
9.	11-053101-000	Set Screw (6 mm x 8 mm)
10.	11-053616-001	Stop Collar (15 mm)
11.	47-041813-004	Bushing
12.	11-053480-001	Speed Nut (10 mm)
13.	47-081654-004	Tension Spring
14.	11-051772-001	Lockwasher (12 mm)
15.	11-053154-001	Jam Nut (12 mm)
16.	99-040400-002	N.A. Sweep Attenuator Hydraulic Complete
	99-046122-000	R.O. Hydraulic Sweep Wagon Assembly
17.	47-045484-004	Bottom Shaft (130 mm)
18.	11-054300-001	Cotter Pin (2 mm)
	11-054301-001	N.A. Hitch Pin (3 mm x 25 mm)
19.	11-051703-001	Hex Nut (10 mm)
20.	11-051771-001	Lockwasher (10 mm)
21.	11-051538-001	Socket Hd. Cap Screw (10 mm x 50 mm)
22.	11-052035-001	Flat Washer (10.5 mm)
23.	47-043583-004	Spacer
24.	99-050230-004	Switch (red box)
25.	11-052206-001	Cap Screw (4 mm x 25 mm)
26.	11-051741-001	Locknut (4 mm)
27.	11-051861-000	Retaining Ring (18 mm)

N.A. = No Longer Available

R.O. = Replacement Option

GS-X
Sweep Attenuator Assembly

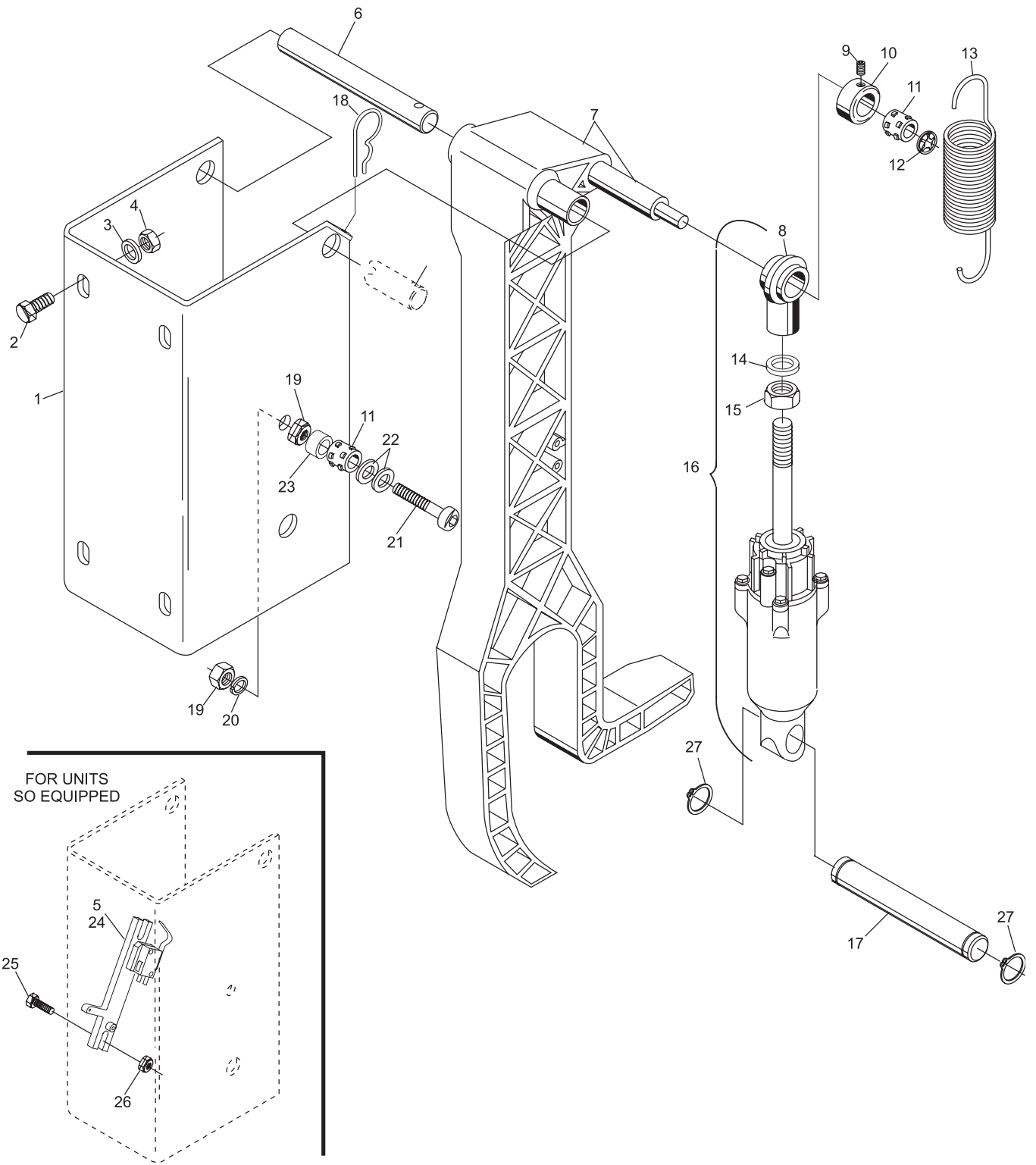

GS-X
Sweep Attenuator Assembly