

Index

No.	Part No.	Description
1.	11-053901-000	V-Belt (10 mm x 6 mm x 875 mm)
2.	11-053101-000	Set Screw (6 mm x 8 mm)
3.	*47-073866-004	Motor Drive Pulley - Dual Sheave (50 or 60 Hz)
	*47-075743-004	Distributor Pulley - 10% reduced speed
4.	11-053501-000	Key (5 mm x 5 mm x 25 mm)
5.	11-051028-001	Hex Hd. Cap Screw (6 mm x 25 mm)
6.	11-052048-001	Flat Washer (6.4 mm)
7.	99-040113-002	N.A. Distributor Motor (1/2 H.P., 230VAC/380VAC)
	99-076263-000	R.O. Distributor Motor (1/2 H.P., 230VAC/380VAC)
	99-040295-004	Distributor Motor (1/2 H.P., 208VAC)
8.	47-070167-004	Bracket
9.	47-075147-003	Motor Mount Bracket
10.	47-095923-004	Tension Spring
11.	11-051743-001	Locknut (6 mm)
12.	99-010102-004	Bearing
13.	11-052036-001	Flat Washer (15 mm)
14.	11-054300-001	Cotter Pin
15.	11-680925-000	N.A. Strain Relief (for all drum brake motors)
	11-055080-000	Strain Relief (for all disc brake motors)
16.	11-051022-001	Hex Hd. Cap Screw (6 mm x 30 mm)
17.	11-055400-000	Circlip

N.A. = No Longer Available

R.O. = Replacement Option

* Replaces 47-073740-004 and 47-071445-004 Single Sheave Motor Drive Pulleys.

Distributor Motor and Mount Assembly

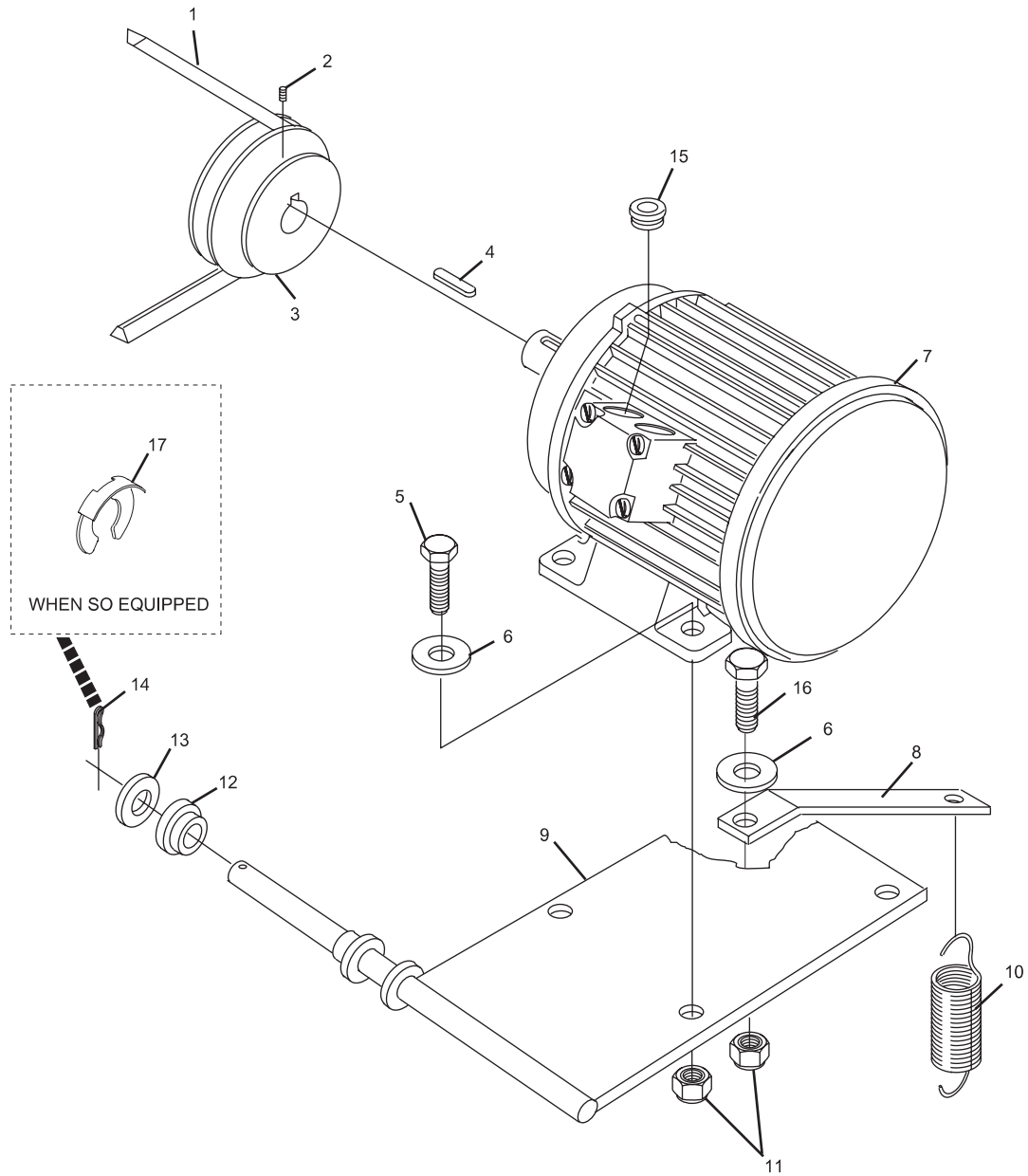

Distributor Motor and Mount Assembly