

Index

No.	Part No.	Description
1.	11-051035-001	Hex Hd. Cap Screw (6 mm x 16 mm)
2.	11-052048-001	Flat Washer (6.4 mm)
3.	11-051743-001	Locknut (6 mm)
4.	47-210446-000	N.A. PCB #11 (GS-10)
5.	47-075188-001	Switch Cluster Frame (Fixed B-Switch)
	47-071876-001	Switch Cluster Frame (Adjustable B-Switch)
6.	47-072307-004	Reed Switch (red box electronics)
7.	47-071879-003	Cam
8.	11-052804-001	Set Screw (6 mm x 8 mm)
9.	47-073534-004	Cherry Switch (red box electronics)
10.	11-052204-001	Sltd. Machine Screw (2.5 mm x 16 mm)
11.	11-051766-001	Lockwasher (2.5 mm)
12.	47-071881-004	Square Shaft Drive Gear
13.	47-071883-004	Clutch Shaft
14.	11-051769-001	Lockwasher (6 mm)
15.	11-051514-001	Socket Hd. Cap Screw (6 mm x 16 mm)
16.	11-051509-001	Socket Hd. Cap Screw (6 mm x 12 mm)
17.	47-071578-004	Bearing Block
18.	47-071880-003	N.A. Gear
	47-071880-003	R.O. Spindle Gear
19.	11-052049-001	Flat Washer (2.7 mm x 6.5 mm x .5 mm)
20.	47-071878-003	Spindle Flange
21.	11-051856-001	Retaining Ring (25 mm)
22.	47-243028-004	Cherry Switch (silver, consolidated and nexgen electronics box)
23.	47-243029-004	Reed Switch (silver, consolidated and nexgen electronics box)
24.	99-050181-004	Reed Switch Holder
25.	11-052354-001	Sltd. Pan Hd. Screw (4 mm x 12 mm)
26.	11-053623-001	Stop Collar (12 mm)

N.A. = No Longer Available

R.O. = Replacement Option

Switch Cluster

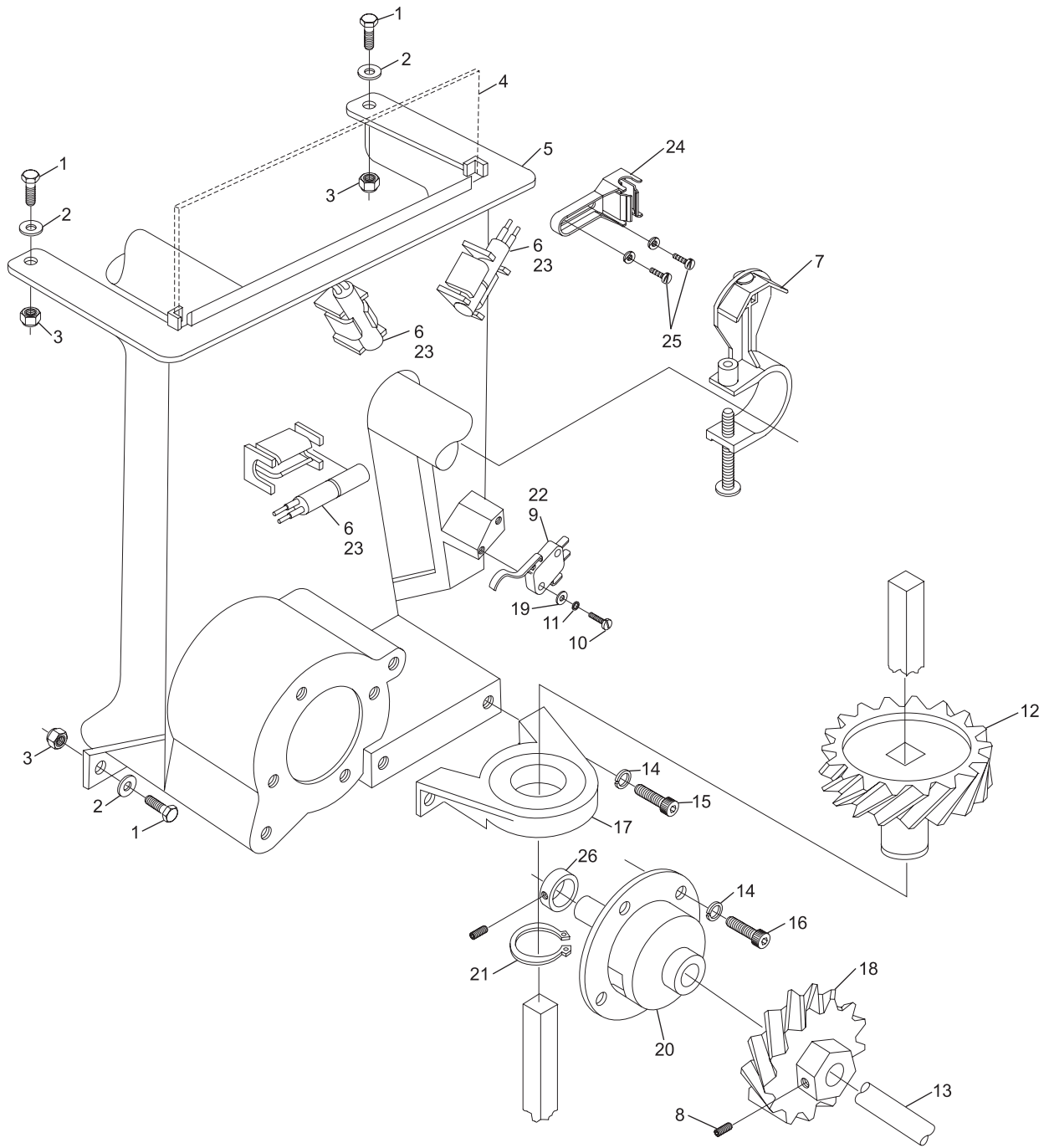

Switch Cluster