

Service Parts Catalog

MAX Lane Machine

October 2021/14-900106-000

Brunswick 

Contents

Section A - Cleaning System

Dusting System	2A
Cleaner Delivery System	4A
Squeegee & Waste System	6A
Squeegee Linkage System	8A

Section B - Chassis & Drive System

Chassis System	2B
MAX Right Side Frame	4B
MAX Left Side Frame	6B
MAX Rear Frame	8B
Traction Drive System	10B
Rear Distance Shaft	12B

Section C - Conditioning System

Conditioning Delivery System	2C
Conditioner Buffing System	4C

Section D - Cover & Handle System

Hood System	2D
Handle System	4D

Section E - Electrical System

Tablet Interface	2E
Electrical Enclosure	4E
Lithium Power	6E
AC/DC Power	8E
Electronic Enclosure - Left Side Video - Cable Assemblies	10E
Electronic Enclosure - Right Side Video - Cable Assemblies	12E
Electronic Enclosure - Rear View - Cable Assemblies	14E
Power Cord	16E

Section F - Miscellaneous

Fuses/ Extraction Tools/ Pins & Sockets	2F
Tubing/Tools/Miscellaneous	3F

MAX Lane Machine Service Parts Catalog

© October 2021 by the Brunswick Bowling Products. All rights reserved.

MAX is a registered trademark of the Brunswick Bowling Products.

Reorder Part No. 14-900106-000

Notice: If available, updates to this catalog can be found on-line at www.brunswickbowling.com.

Confidential proprietary information. All information contained in this document is subject to change without notice.

Brunswick Bowling Products
525 West Laketon Avenue
Muskegon, MI 49441
U.S.A.
231-725-3300

Select Only Genuine Brunswick Replacement Parts for Brunswick Equipment

You purchased the best when you bought Brunswick equipment. Insist on the best in replacement parts. Buy Genuine Brunswick Replacement Parts to keep your equipment in top-notch working condition.

Here's why you should insist on Brunswick Replacement Parts for your Brunswick equipment:

- Only Brunswick replacement parts are guaranteed to be the same, top quality, heavy-duty parts that go into the world's finest equipment by Brunswick.
- Rigid quality control assures maximum protection against part defect or failure.
- Full-time testing of all equipment and continual updating of parts provides the latest improvements.
- Each improved part is designed to be interchangeable with the part it is replacing.
- Efficient cost methods of production and design, reduce the cost of parts.

To place an order contact your certified Brunswick parts distributor or Brunswick at 1-800-YES-BOWL or 231-725-3300. Authorized Brunswick part distributors listings can be found on-line at www.brunswickbowling.com

For catalog comments or questions please e-mail: aftermarketcatalogs@brunbowl.com

WARRANTY

- Warranty coverage starts with date of purchase.
- The warranty coverage period is 90 days on materials.
- Repair or replacement parts is at the option of Brunswick.
- Call your authorized Brunswick Parts Distributor for parts warranty transaction process.

Intentionally Blank Page

Section A
Cleaning System

Index

No.	Part No.	Description
1.	11-601013-000	Roller Chain
2.	11-600010-000	Master Link Assembly (1/4" #25)
3.	11-491104-000	Sprocket (23 Tooth, 3/8 Bore)
4.	11-007124-000	Flat Head Hex Socket Cap Screw (#10-32 x 1")
5.	11-006125-000	Button Head Socket Cap Screw (#10-32 x 1")
6.	11-195010-015	Lockwasher (#10)
7.	11-190006-015	Plain Washer (#10)
8.	14-100724-005	Duster Motor w/Connector
9.	14-100364-000	Friction Clutch Assembly w/Hardware
10.	62-860207-000	Envoy/Authority 22 Cleaning Cloth - Package
11.	11-106650-000	Socket Head Shoulder Screw (5/16-18 x 3/8 x 5/8")
12.	14-100084-000	Contact Roller Pivot Arm
13.	11-191752-000	Washer (3/8)
14.	14-100204-000	Duster Cloth Stiffener
15.	14-100081-002	Duster Foam Tube (1.62 I.D. x .75" x 43")
16.	11-005178-015	Hex Head Socket Cap Screw (1/4-20 x 1/2")
17.	11-500100-000	Roller Bearing (3/8 x 7/8 x 9/32)
18.	11-192577-000	Shim (.376 I.D. x .563 O.D. x .010 Thick)
19.	11-190554-015	Fender Washer (11/64 Id x .75 O.D.)
20.	11-006063-009	Button Head Cap Screw (#8-32 x 1/2")
21.	14-100078-000	Duster Cloth Take Up Hub Assembly
22.	14-100780-000	Duster Take-Up Drive Shaft Assembly
23.	11-105451-000	Hex Socket Set Screw (#10-32 x .25")
24.	11-006009-000	Button Head Socket Cap Screw (#4-40 x 7/8")
25.	11-199000-015	Internal Tooth Lockwasher (#4)
26.	11-616025-000	Duster Cloth Up/Dn Lever Type Switch
27.	11-170000-015	Locknut (#4-40)
28.	11-171504-000	Serrated Flange Hex Nut (1/4-20)
29.	11-171501-000	Serrated Flange Hex Nut (5/16-18)
30.	61-200008-000	Duster Cloth Core W/ Plug Assembly
31.	14-100081-000	Contact Roller Duster Cloth Assembly

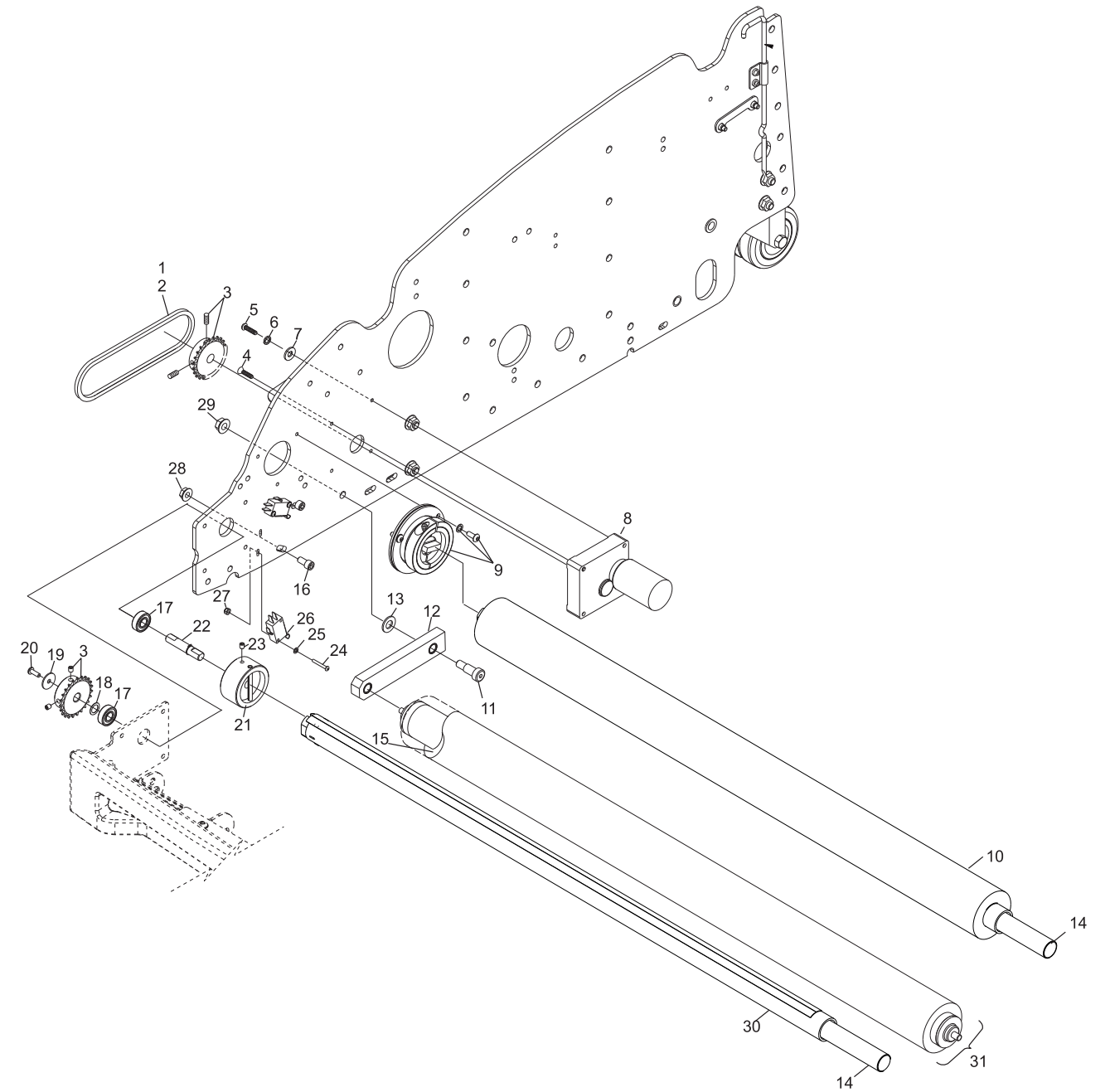

Dusting System

Dusting System

Index

Index No.	Part No.	Description
1.	14-100944-000	Supply Tank Assembly
2.	11-655037-000	Vent Valve
3.	14-100942-000	Level Float Sensor
4.	14-100406-000	Line Strainer Assembly
5.	11-655052-000	90° Elbow Fitting (1/4" tube x 3/8" stem)
6.	11-655043-006	Tubing - 3/8" (20')
7.	14-100758-091	Cleaner Pump Assembly
8.	11-010782-000	Hex Head Serrated Flange Cap Screw (1/4-20 x 1/2")
9.	11-655041-000	Elbow Fitting (3/8 tube 1/4 NPT)
10.	11-655053-000	90° Elbow Fitting (3/8")
11.	14-100864-002	Nozzel Holder Bracket (right hand)
12.	14-100449-000	Cap w/Seal
13.	14-100440-002	Tank Mounting Bracket (left hand)
14.	11-655039-001	Tube (1/4 O.D. x 1.25")
15.	11-655038-000	Check Valve (1/8 x 1/8)
16.	14-100440-001	Tank Mounting Bracket (right hand)
17.	11-014265-000	Screw (1/4-20 x 1/2")
18.	11-655074-000	Nozzel Body - Female (1/4 x 11/16-16)
19.	14-100430-001	Grommet
20.	11-625602-000	O-Ring (11/32)
21.	14-100430-000	Grommet
22.	11-282004-002	Tubing (3/8" x 10-3/8")
23.	14-101438-000	Pump Mounting Bracket
24.	11-191753-000	Washer
25.	11-170005-015	Lock Nut (#10-24)
26.	11-006061-015	Screw (#8-32 x 3/8")
27.	11-199002-015	Lockwasher (#8)
28.	11-655058-000	Tool Holder
29.	11-185257-000	Standoff (#8-32 x 1-1/4")
30.	11-199003-015	Lockwasher (#10)
31.	11-006095-000	Screw (#10-24 x 1-1/4")
32.	11-655086-000	Strainer w/Check Valve (100 mesh screen)
33.	11-655070-000	Spray Tip - 110 Deg (.05 GPM)
34.	11-655004-000	Spray Cleaner Tip Retainer
35.	11-655080-000	Tee Fitting (3/8" Tube to 1/4 NPT)
36.	11-655048-000	Connector Fitting (3/8")
37.	11-655084-004	Line Strainer (100 Mesh)
38.	14-100877-000	Union Plate
39.	11-655087-000	Y - Union (3/8" Dia. Tube)
40.	11-603003-000	Loop Clamp (5/8")
41.	11-012058-015	Screw (#8-32 x 3/8")
42.	14-100864-001	Nozzel Bracket (left hand)
43.	11-655075-000	Ball Valve (1/8 NPT Male-Female)
44.	14-100879-000	Cleaner Manifold Body
45.	11-655076-000	Nipple Reducer - Hex Male (1/4 NPT to 1/8 NPT)
46.	11-655071-000	Adjustment Valve - Bi-Directional Flow Control
47.	11-655048-000	Male Connector Fitting (3/8" Tube x 1/4 NPT)
48.	11-655063-000	Male Connector Fitting (3/8" Tube x 1/8 NPT)
49.	11-696974-000	Sensor - Pressure Cleaner
50.	11-655057-000	Fitting - 90° Degree Elbow
51.	11-655065-000	Pressure Gauge (2 Dia. 0-60 PSI)
52.	14-101910-000	Cleaner Manifold Assembly (MAX)
53.	14-860035-000	Pkg. Y - Union (3/8")

Cleaner Delivery System

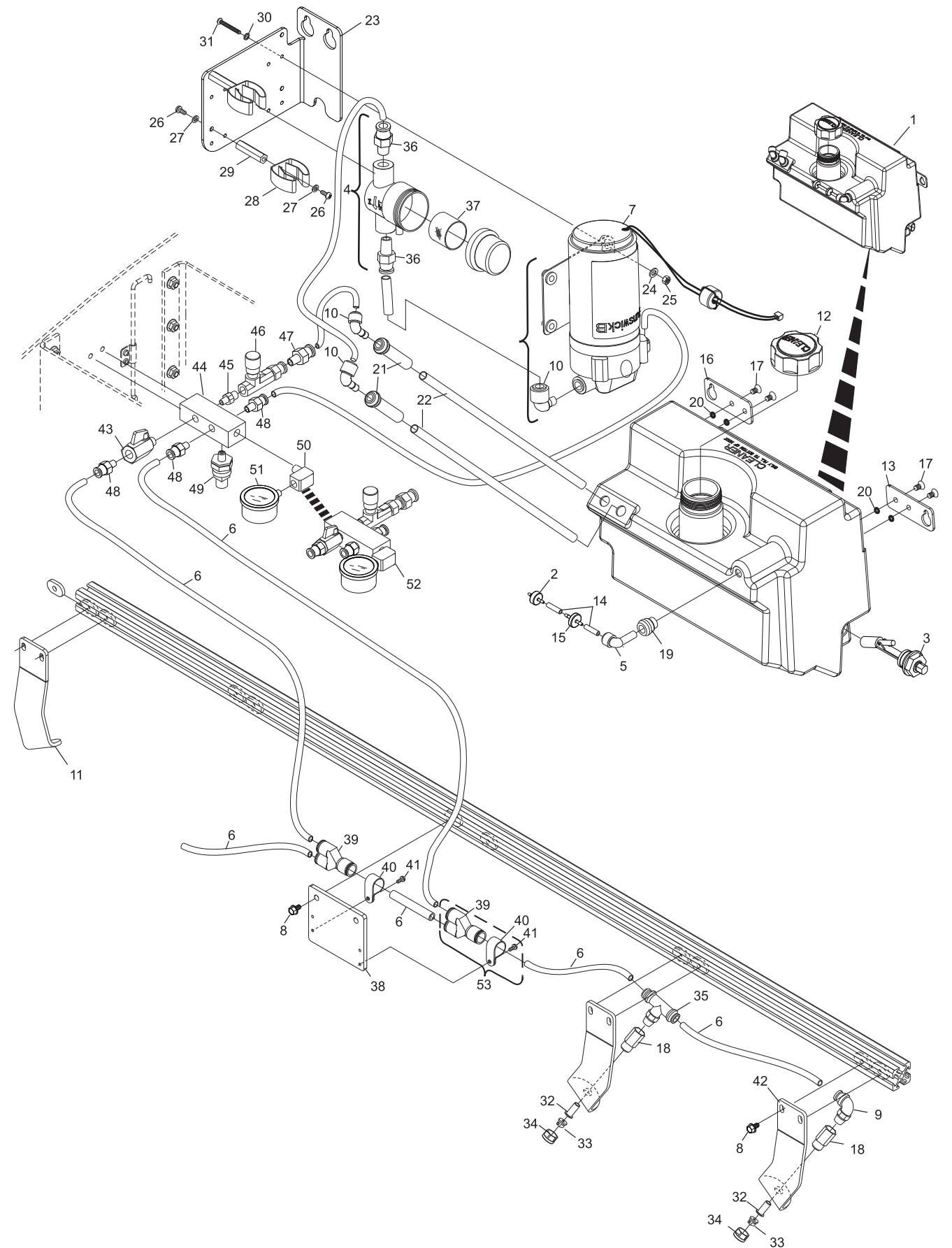

Cleaner Delivery System

Index

Index No.	Part No.	Description
1.	11-616026-000	Switch - Roller Lever, SPDT
2.	14-101060-000	Pivot Arms
3.	14-100065-000	Lifting Linkage
4.	14-100914-000	Vacuum Motor Assembly
5.	14-100301-000	Waste Tank
6.	14-100917-000	Vacuum Hose Assembly
7.	11-655078-002	Hose
8.	11-655077-000	Hose Cuff
9.	14-101061-000	Lift Rod
10.	11-537051-000	Retaining Ring (external)
11.	11-192576-000	Shim
12.	11-388000-000	Spacer (1/4" I.D. x 1/2" O.D. x 1-1/4")
13.	11-005193-015	Screw (1/4-20 x 2-1/4")
14.	11-190010-015	Flat Washer (1/4)
15.	14-100093-000	Vacuum Motor Bracket
16.	11-005186-015	Socket Head Cap Screw (1/4-20 x 1-1/4")
17.	11-171504-000	Hex Serrated Head Nut (1/4-20)
18.	14-100097-000	Vacuum Exhaust Deflector Assembly
19.	11-006116-000	Screw (#10-32 x 3/8")
20.	11-199003-015	Lock Washer (#10)
21.	14-100066-000	Vacuum Exhaust Deflector
22.	14-100106-000	Side Exhaust Deflector Felt
23.	14-860222-000	Adhesive (for felt)
24.	14-100104-000	Top Exhaust Deflector Felt
25.	14-100377-000	Diffuser Bracket
26.	14-101764-000	Motor Mount Bracket
27.	11-006010-000	Screw (#4-40 x 1")
28.	11-199000-015	Internal Tooth Lockwasher (#4)
29.	11-199003-015	Nut (#8-32)
30.	11-696701-000	Connector Housing
31.	14-100724-022	Motor Assembly
32.	11-006125-000	Screw (#8-32 x 1-1/2")
33.	14-100729-000	Squeegee Up/Down Cam
34.	11-105454-000	Set Screw (1/4-28 x 3/8")
35.	14-101763-000	Assembly - Squeegee Up/Down Mechanism
36.	11-007180-015	Flat Head Screw
37.	11-106550-009	Bolt (5/16 x 3/8 x 3/8")
38.	14-100850-000	V-Squeegee Assembly - complete
39.	14-100258-000	Up/Down Switch Cable Assembly
40.	11-007776-000	Flat Head Cap Screw (1/4-20 X 5/8")
41.	14-100848-000	Inner Squeegee Extrusion (left hand)
42.	11-170007-015	Locknut w/Nyloc Insert (1/4-20)
43.	11-007775-000	Flat Head Cap Screw (1/4-20 X 1/2")
44.	14-100523-091	V-Squeegee Blade Assembly
45.	14-100849-000	Inner Squeegee Extrusion (right hand)
46.	14-100556-091	Absorbent Wiper Assembly
47.	14-100488-000	Alignment Pin
48.	14-100455-002	Outer Squeegee Extrusion (right hand)
49.	14-100458-002	Arm Bracket (right hand)
50.	14-100460-000	Vacuum Head Assembly
51.	14-100458-001	Arm Bracket (left hand)
52.	14-100455-001	Outer Squeegee Extrusion (left hand)
53.	11-007777-000	Flat Head Cap Screw (1/4-20 x 3/4")
54.	11-696736-000	Terminal - Male
55.	11-191752-000	Flat Washer

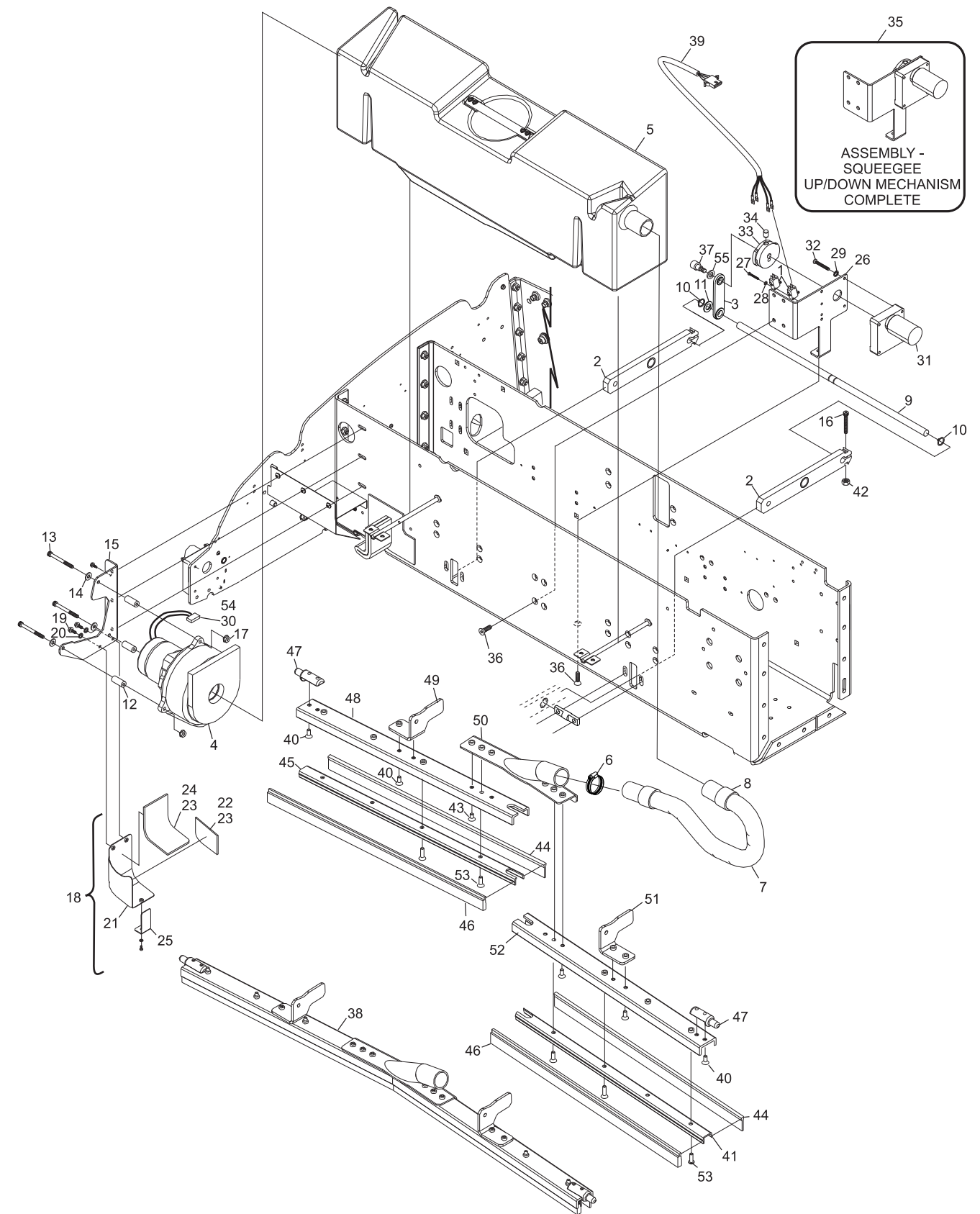

Squeegee & Waste System

Squeegee & Waste System

Index

No.	Part No.	Description
1.	11-010787-000	Hex Serrated Flange Head Screw (5/16-18 x 1")
2.	11-007184-015	Hex Head Flange Screw (1/4-20 x 1")
3.	14-101420-015	Hex Head Cap Screw (1/4-20 x 4-1/2")
4.	14-101295-002	Squeegee Adjustment Bracket - R.H.
5.	14-100213-000	Skid Plate
6.	11-170007-015	Locknut w/Nyloc Insert (1/4-20)
7.	14-100254-000	Assembly - Speed Sensor
8.	14-101540-000	Speed Sensor Bracket
9.	14-101295-001	Squeegee Adjustment Bracket - L.H.
10.	14-101060-000	Pivot Arms
11.	11-537051-000	Retaining Ring (external)
12.	11-192576-000	Shim
13.	14-100065-000	Lifting Linkage
14.	14-101061-000	Lift Rod
15.	11-005186-015	Socket Head Cap Screw (1/4-20 x 1-1/4")
16.	11-170007-015	Locknut (1/4-20)
17.	14-101425-000	Squeegee Pivot Block
18.	14-101068-000	Assembly - Squeegee Lift Linkage
19.	11-007180-015	Flat Head Hex Socket Screw (1/4-20 x 5/8")
20.	11-171504-000	Serrated Flange Hex Nut (1/4-20)

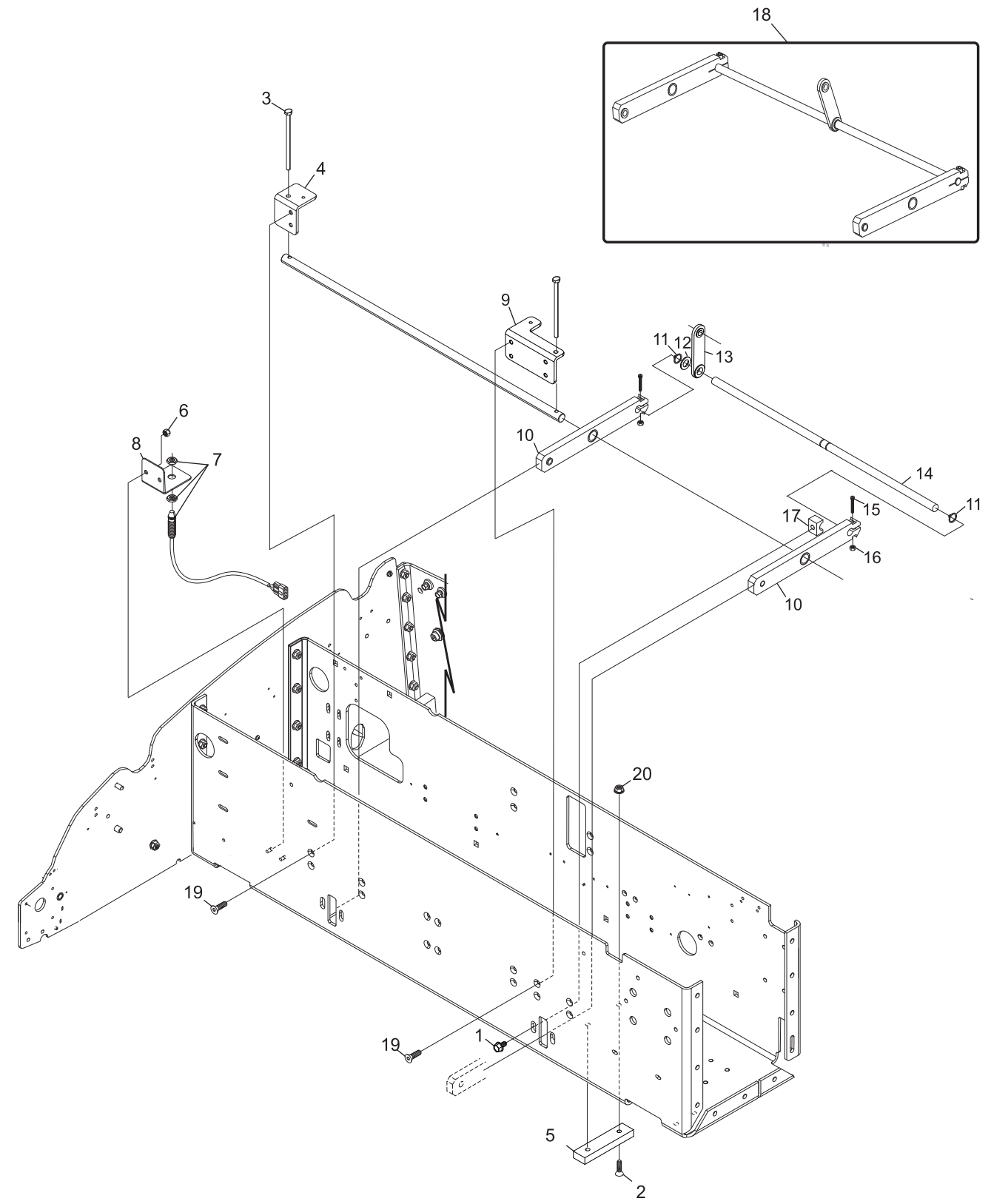

Squeegee Linkage System

Squeegee Linkage System

Intentionally Blank Page

Section B

Chassis & Drive System

**Index
No.**

Index No.	Part No.	Description
1.	14-100776-000	Front Handle/Bumper
2.	14-100235-091	End of Lane Sensor
3.	11-199005-015	Internal Tooth Lockwasher (1/4)
4.	14-100777-001	Front Handle/Bumper Bracket (left hand)
5.	14-860241-002	Transition/Guide Wheel Assembly (right hand)
6.	14-860241-001	Transition/Guide Wheel Assembly (left hand)
7.	11-625601-000	O-Ring
8.	14-100777-002	Front Handle/Bumper Bracket (right hand)
9.	11-010790-000	Hex Head Serrated Flange Screw (1/4-20 x 3/8")
10.	11-006177-015	Button Head Cap Screw (1/4 x 3/8")
11.	14-100101-000	T-Nut (1/4-20)
12.	11-191014-015	Flat Washer (3/8)
13.	11-005266-015	Socket Head Cap Screw (5/16-18 x 1-1/2')
14.	11-171501-000	Hex Nut (5/16-18)
15.	14-100732-000	Wheel (6")
16.	11-611610-000	Dome Plug
17.	11-054110-015	Washer - Thick (10 mm)
18.	11-005514-015	Socket Head Cap Screw (1/2-13 x 2-1/2")
19.	11-190010-015	Washer (1/4)
20.	11-006218-015	Button Head Socket Cap Screw (1/4-28 x 1/2")
21.	11-185281-000	Spacer (1/2 x 1/16 x 1/32")
22.	14-100531-000	Transition Wheel Assembly
23.	11-185279-000	Spacer (1/2 I.D. x 1/32")
24.	14-100279-000	Front Guide Wheel
25.	11-581010-000	Compression Spring
26.	14-100731-000	Wheel Mount
27.	14-100730-000	Caster Bracket
28.	11-010787-000	Hex Head Serrated Flange Screw (5/16-18)
29.	11-192576-000	Shim (1/2 I.D. x 7/8 O.D.)
30.	14-100207-000	Front Brace/Transition Wheel Assembly
31.	14-100030-000	Guide Wheel
32.	14-100139-000	Swivel Caster Assembly (3")
33.	14-100138-000	Swivel Caster (3")
34.	11-002246-015	Hex Head Cap Screw (1/2-13 x 1-1/2")
35.	11-195018-015	Lockwasher (1/2)
36.	14-100036-000	Guide Wheel Assembly
37.	11-171505-015	Hex Serrated Flange Nut (1/2-13)

* Not Illustrated

Chassis System

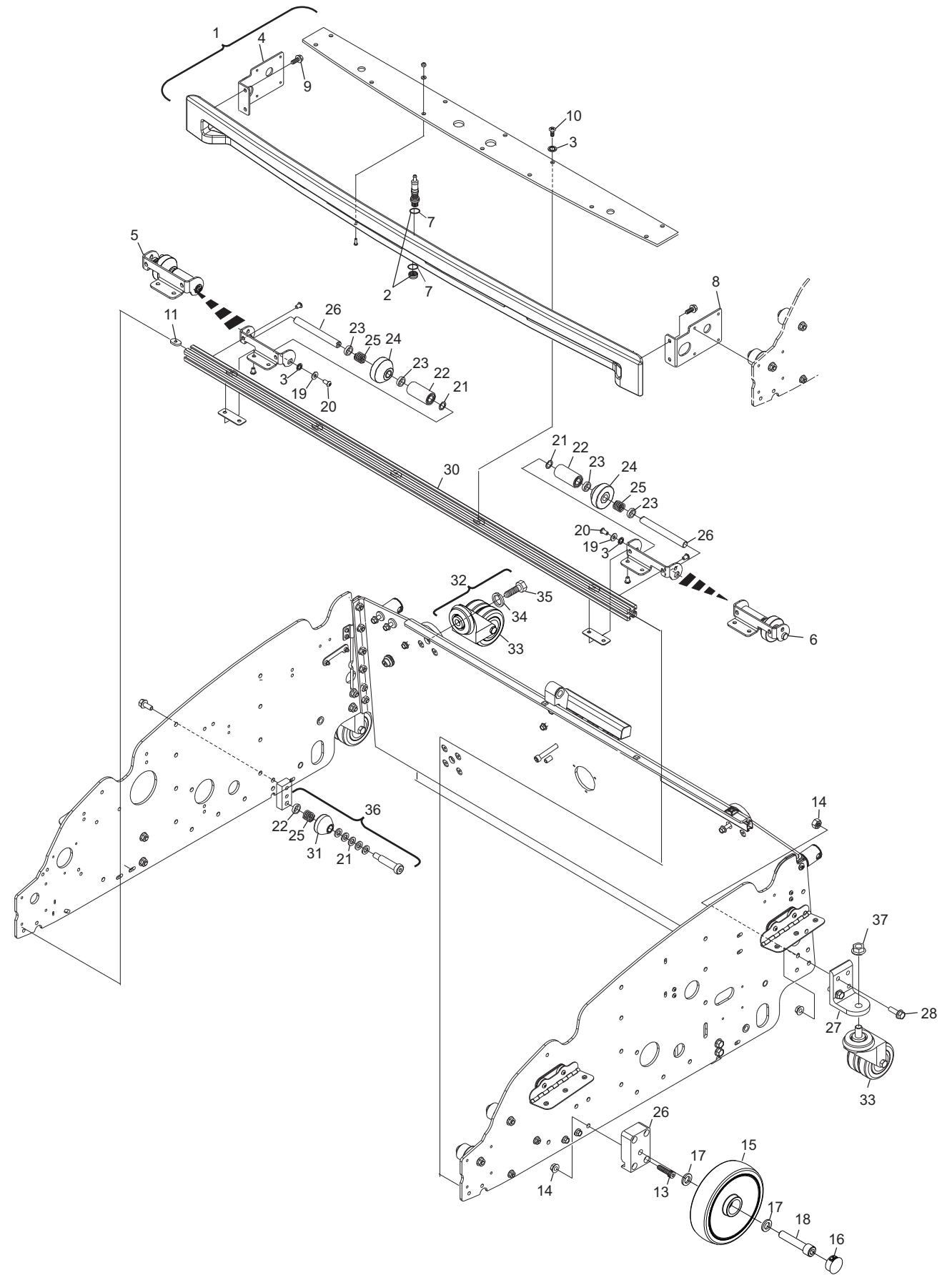

Chassis System

Index

Index No.	Part No.	Description
1.	14-100730-000	Caster Bracket
2.	11-010787-000	Hex Flange Head Screw (5/16-18 x 1")
3.	11-171501-000	Nut (5/16-18)
4.	14-100139-000	Swivel Caster (3" Dual Wheel)
5.	11-171505-015	Serrated Flange Nut (1/2-13)
6.	14-100123-000	Hinge
7.	11-192028-000	Spacer
8.	14-100373-000	Shim
9.	14-100312-000	Nut Plate Assembly - Cover Hinges
10.	14-100712-000	Side Frame - R.H.
11.	11-006063-009	Button Head Socket Cap Screw (#8-32 x 1/2")
12.	11-199002-015	Lock Washer (#8)
13.	14-100876-000	Cover Pin Guide
14.	14-100875-001	Cover Pin - Rear
15.	14-100875-002	Cover Pin - Middle
16.	14-100036-000	Assembly - Guide Wheel
17.	11-010783-000	Hex Serrated Flange Head Screw (5/16 x 18 x 3/4")
18.	14-100724-005	Assembly - Gear Motor w/Connector
19.	11-006125-000	Button Head Socket Cap Screw (#8-32 x 1")
20.	11-195010-015	Lock Washer (#10)
21.	11-190006-015	Flat Washer (#10)
22.	11-191752-000	Washer
23.	14-100731-000	Wheel Mount
24.	11-005266-015	Socket Head Cap Screw (5/16-18 x 1-1/4")
25.	11-010784-000	Hex Serrated Flange Head Screw (1/4-20 x 1-1/4") Stainless Steel
26.	14-100953-000	V-Squeegee Guide Block
27.	11-171502-000	Nut 1/4-20 Stainless Steel
28.	14-100364-000	Assembly - Friction Clutch w/Hardware
29.	14-100084-000	Pivot Arm
30.	11-106650-000	Socket Head Shoulder Screw (5/16-18 x 3/8" x 5/8")
31.	11-491104-000	Sprocket - 23 Tooth w/Set Screws
32.	11-005178-015	Screw Socket Head Cap (1/4-20 x 1/2")
33.	11-171504-000	Nut (1/4-20)
34.	11-170000-015	Nut (#4-40) Locknut
35.	11-616025-000	Switch - Duster Cloth Start/Stop
36.	11-199000-015	Lockwasher (#4)
37.	11-010783-000	Hex Serrated Flange Head Screw (5/16-18 x 3/4")
38.	11-650002-000	Bumper

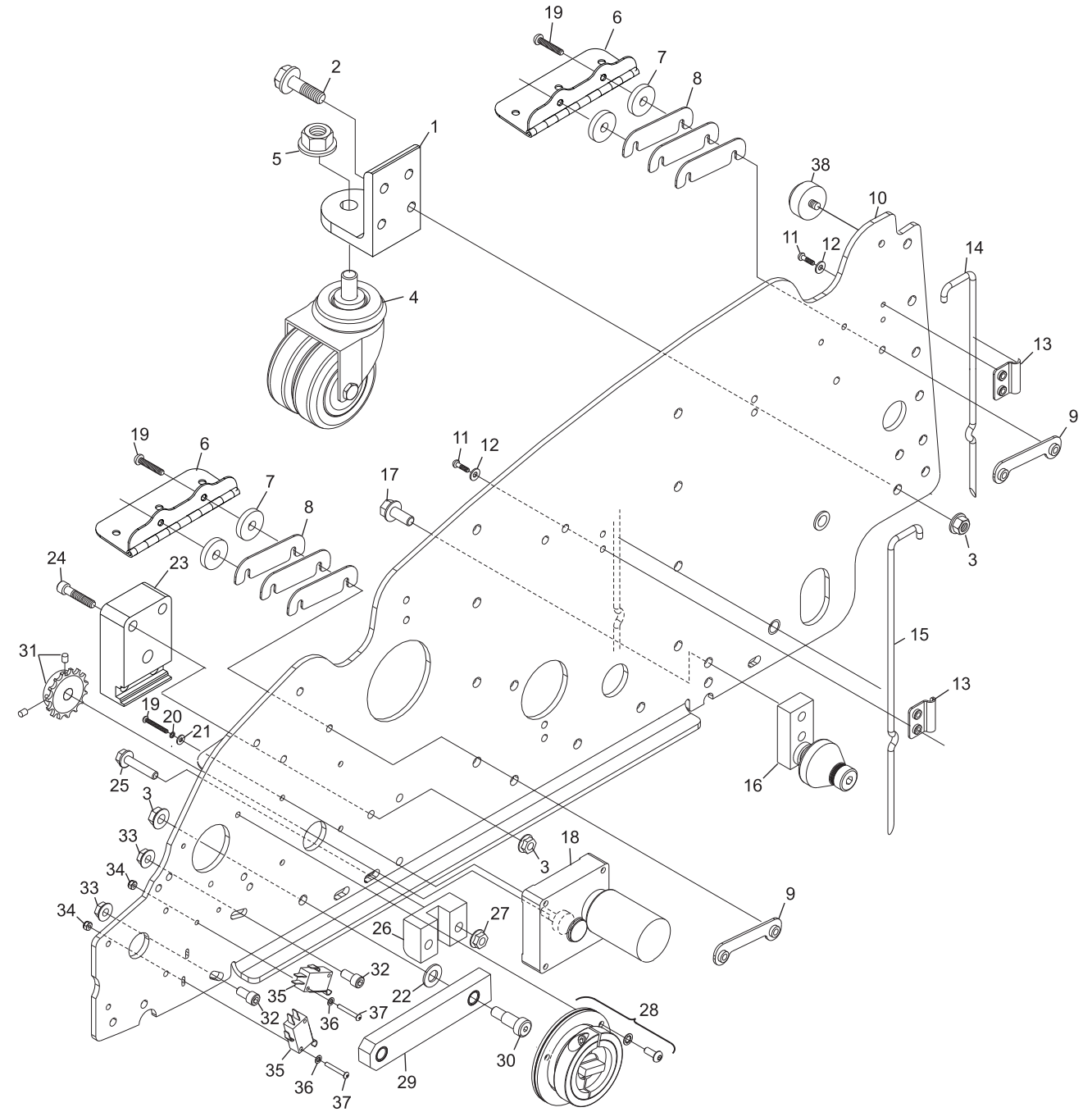

MAX Right Side Frame

MAX Right Side Frame

Index

No.	Part No.	Description
1.	14-100123-000	Hinge
2.	11-192028-000	Spacer
3.	14-100373-000	Shim
4.	14-100312-000	Nut Plate Assembly - Cover Hinges
5.	14-100730-000	Caster Bracket
6.	11-010787-000	Hex Flange Head Screw (5/16-18 x 1")
7.	11-171501-000	Nut (5/16-18)
8.	14-100139-000	Swivel Caster (3" Dual Wheel)
9.	11-171505-015	Serrated Flange Nut (1/2-13)
10.	14-101701-000	L.H. Side Frame - Assembly
11.	11-006063-009	Button Head Socket Cap Screw (#8-32 x 1/2")
12.	11-199002-015	Lock Washer (#8)
13.	14-100876-000	Cover Pin Guide
14.	14-100875-001	Cover Pin - Rear
15.	14-100875-002	Cover Pin - Middle
16.	14-100036-000	Assembly - Guide Wheel
17.	11-106648-000	Shoulder Bolt (1/2 x 1.75")
18.	11-185281-000	Spacer (1/2 ID x 11/16 OD)
19.	14-100030-000	Guide Wheel
20.	11-581010-000	Compression Spring
21.	11-185279-000	Spacer
22.	14-100031-000	Mounting Block
23.	11-010783-000	Hex Serrated Flange Head Screw (5/16 x 18 x 34")
24.	14-100731-000	Wheel Mount
25.	11-005266-015	Socket Head Cap Screw (5/16-18 x 1-1/4")
26.	11-010784-000	Hex Serrated Flange Head Screw (1/4-20 x 1-1/4") Stainless Steel
27.	14-100953-000	V-Squeegee Guide Block
28.	11-171502-000	Nut 1/4-20 Stainless Steel
29.	11-106557-009	Socket Head Shoulder Bolt (5/16-18 X 3/8" X 1-3/4")
30.	14-100080-000	Duster Cloth Hub
31.	11-655059-000	Compression Spring
32.	11-005178-015	Socket Head Cap Screw (1/4-20 x 1/2")
33.	11-171504-000	Nut (1/4-20)
34.	11-650002-000	Bumper

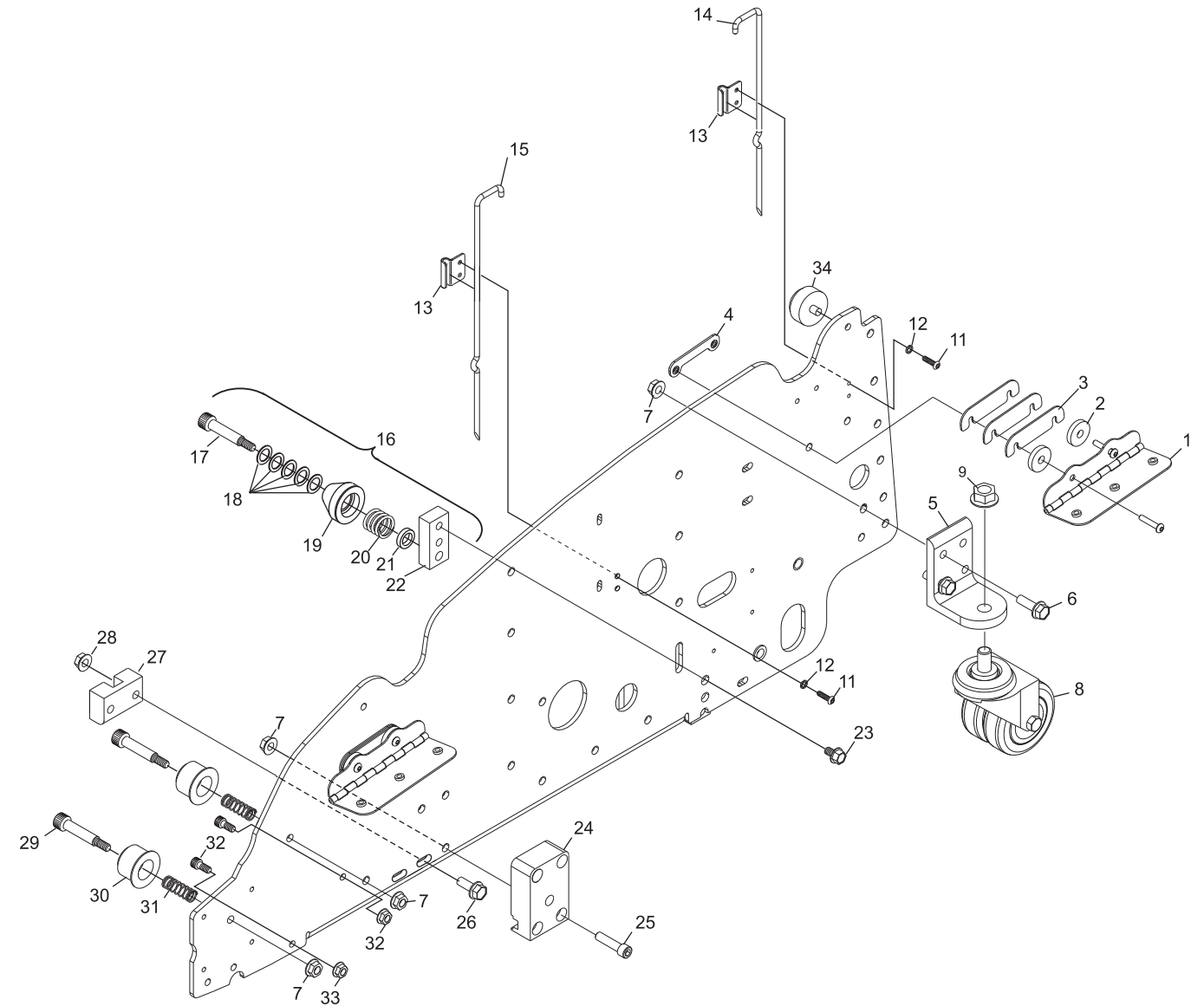

MAX Left Side Frame

MAX Left Side Frame

Index

No.	Part No.	Description
1.	14-101703-000	Assembly - Rear Frame
2.	14-100713-000	Rear Frame - only
3.	11-010785-000	Hex Serrated Flange Head Screw (1/4-20 x 3/4")
4.	11-652054-000	Rubber Washer (1/4 ID x 3/4 O.D.)
5.	11-010782-000	Hex Serrated Flange Head Screw (1/4-20 x 1/2")
6.	11-106650-000	Socket Head Shoulder Screw (5/16-18 x 3/8" x 3/8")
7.	11-651033-000	Grommet (.375 I.D. x .875 O.D.)
8.	11-171501-000	Nut (5/16-18)
9.	14-100069-000	Caster Mount Plate
10.	11-007180-015	Screw Flat Head Socket Cap (1/4-20 x 3/4")
11.	14-100541-000	Speed Sensor w/Foam, Bracket
12.	14-100959-000	Lower Caster Mount Plate
13.	11-010783-000	Screw Hex Serrated Flange Head (5/16-18 x 3/4")
14.	11-005272-015	Screw Socket Head Cap (5/16-18 x 2")
15.	14-100439-000	Lower, Tank Support Bracket
16.	14-100254-000	Assembly - Speed Sensor w/Cable
17.	14-100134-001	Hinge Bracket R.H. Handle
18.	11-010789-000	Hex Flange Head Screw (5/16-18 x 1-1/4")
19.	14-100543-000	Assembly - Over Travel Block
20.	11-603131-000	Cable Tie Mount
21.	14-100434-000	Assembly - Buffer Brush Shield w/Felt
22.	11-199003-015	Lock Washer (#10)
23.	11-006118-015	Button Head Socket Cap Screw (10-32 x 1/2")
24.	14-100752-000	Battery Tray Bracket
25.	14-100254-000	Assembly - Speed Sensor w/Cable
26.	14-100499-000	Assembly - Rear Shaft Wheels, Urrethane
27.	11-603105-000	Cable Tie (7.25" x .19")
28.	11-650012-000	Bumper (.50 x .50 x .23) w/Adhesive Backing

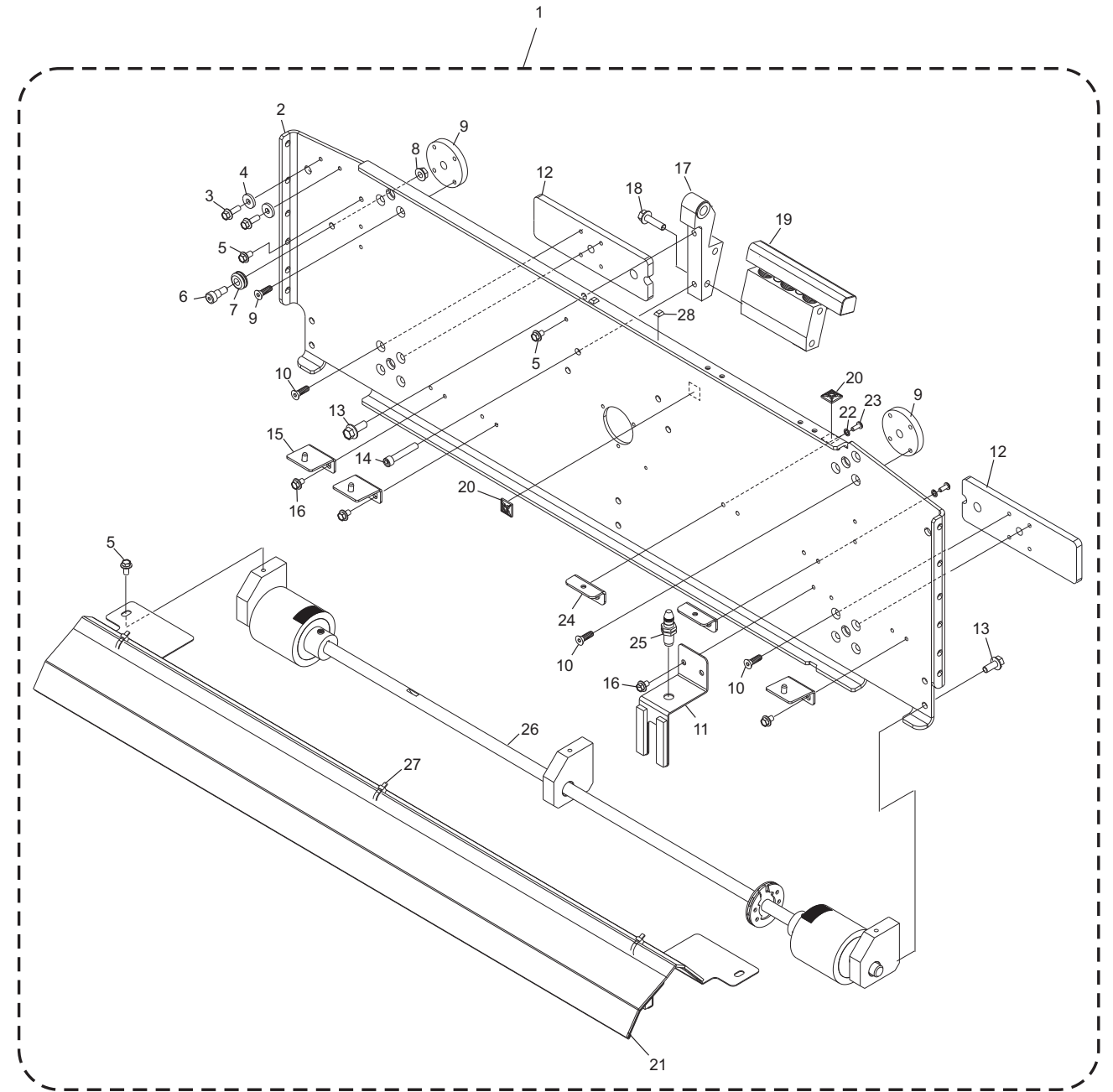

MAX Rear Frame

MAX Rear Frame

Index

No.	Part No.	Description
1.	14-100766-000	Drive Motor w/Cable Assembly
2.	11-002033-015	Screw (1/4-28 - 5/8")
3.	11-195014-015	Lockwasher (1/4)
4.	11-190010-015	Flat Washer (1/4)
5.	14-100005-001	Motor Mount Bracket
6.	11-491103-000	Sprocket (12 tooth)
7.	11-601011-000	Roller Chain
8.	11-171504-000	Nut (1/4-20)
9.	14-100767-000	Drive Motor Assembly w/Bracket
10.	11-600001-000	Connecting Link (roller chain)
11.	14-100470-000	Drive Wheel Assembly (urethane)
12.	11-105452-000	Set Screw (5/16-24 x 3/8")
13.	11-050007-000	Woodruff Key
14.	11-491101-000	Sprocket (10 tooth)
15.	14-100015-000	Drive Shaft
16.	14-100026-000	Bearing Block (short shaft)
17.	14-101484-000	Drive Shaft Wheel Assembly
18.	11-010785-000	Screw (1/4-20 x 3/4")
19.	14-100584-000	Shield
20.	14-100073-000	Wheel Speed Sensor
21.	11-293010-000	Rivet

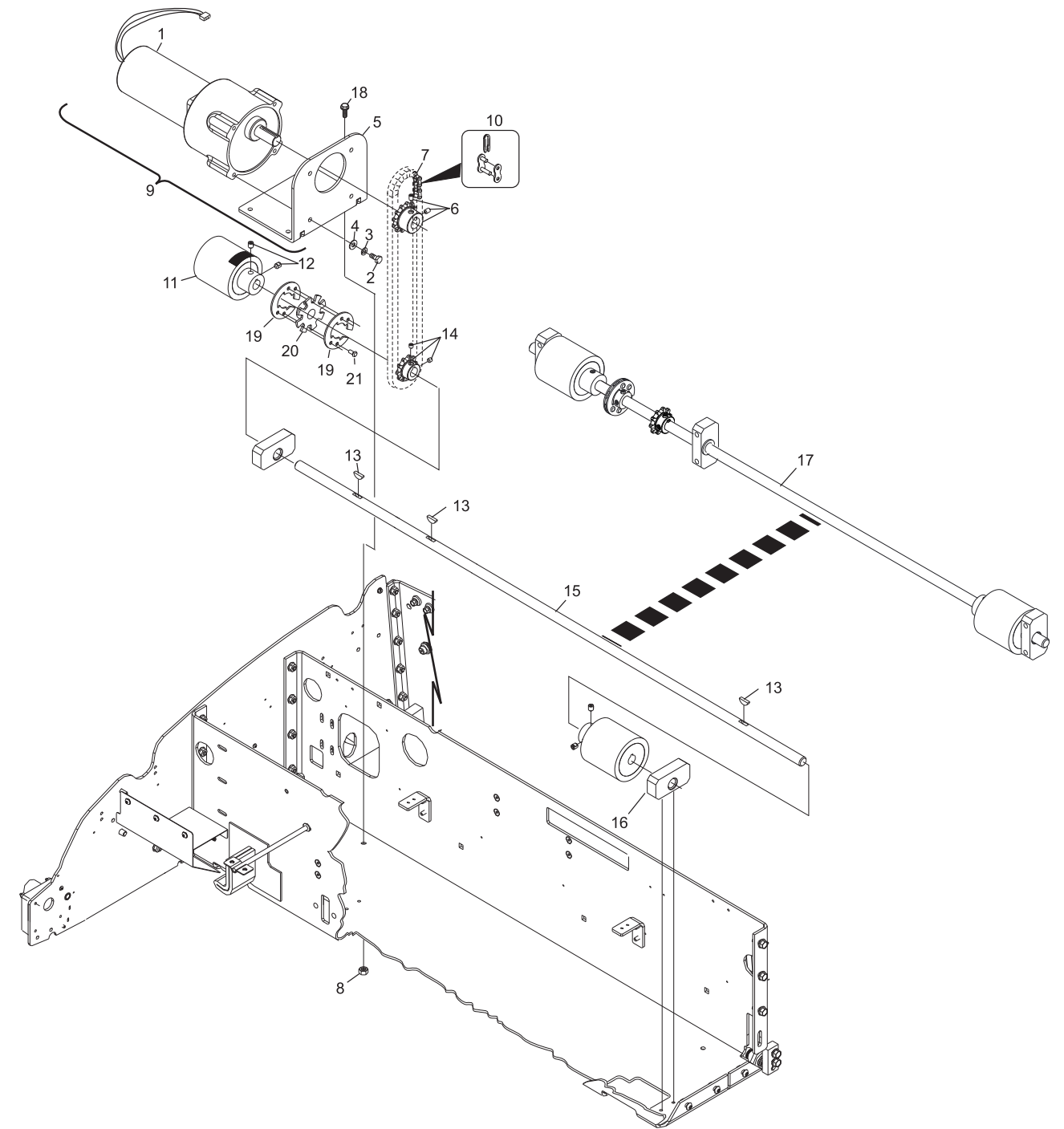

Traction Drive System

Traction Drive System

Index

No.	Part No.	Description
1.	14-100254-000	Speed Sensor Assembly
2.	14-100541-000	Speed Sensor Bracket
3.	11-010790-000	Hex Head Serrated Flange Screw (1/4-20 x 3/8")
4.	14-100073-000	Position Sensor Wheel Assembly
5.	14-860225-000	Distance Encoder Sprocket Shield
6.	14-100059-001	Bearing Block (left hand)
7.	14-100470-000	Drive Wheel Assembly
8.	11-050007-000	Woodruff Key (3/16 x 3/4)
9.	11-105452-000	Set Screw (5/16-24 x 3/8")
10.	14-100015-000	Drive Shaft
11.	14-100059-002	Bearing Block (right hand)
12.	11-420144-000	Bearing Sleeve (5/8 ID x 13/16 OD)

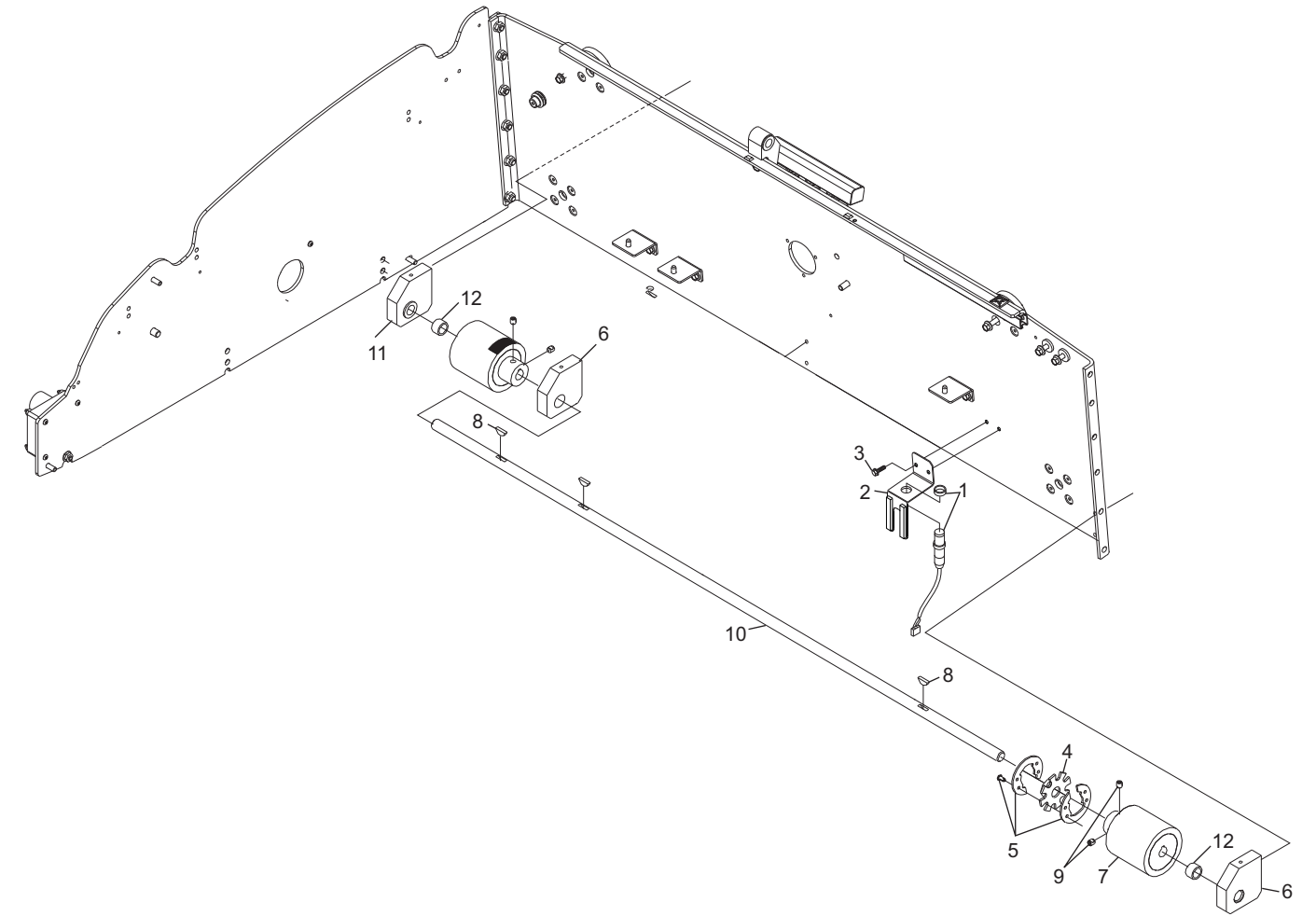

Rear Distance Shaft

Rear Distance Shaft

Intentionally Blank Page

Section C

Conditioning System

Index
No. Part No.

Index No.	Part No.	Description
1.	14-100725-000	Solenoid Valve w/Connector Assembly (24VDC)
2.	11-655016-000	Filter/Muffler
3.	14-100090-000	Mounting Bracket
4.	11-012056-015	Screw (#8-32 x 1/4)
5.	11-655015-000	Male Fitting (1/4 Tube x 1/8 NPT)
6.	14-100025-000	Vent Overflow Line Strainer
7.	11-655026-000	Swivel Elbow Fitting
8.	11-655044-000	Line Strainer (200 mesh)
9.	14-101791-000	Conditioner Tank Assembly - complete
10.	11-006095-000	Button Head Cap Screw (#10-24 x 1-1/4")
11.	11-655052-000	90° Elbow Fitting (3/8 tube x 3/8 stem)
12.	14-100430-001	Grommet (modified)
13.	14-100437-000	Conditioner Tank Cap
14.	11-655063-000	Straight Fitting (1/8 NPT)
15.	11-655015-000	Straight Fitting (1/8 NPT)
16.	14-101942-000	Liquid Level Sensor
17.	11-655065-000	Pressure Dial (0-6 PSI)
18.	11-655040-000	Fitting (3/8 Tube to 3/8 NPT)
19.	11-696945-000	Sensor Pressure (100 PSI)
20.	14-100580-000	Foam - Conditioner Tank Neck
21.	11-655090-000	3/8" Tube Straight Union
22.	11-282004-004	Tubing (3/8 O.D. x 11-1/4")
23.	14-100478-000	Line Strainer Assembly
24.	11-655048-000	Connector Fitting (3/8)
25.	11-655024-000	Line Strainer (40 mesh)
26.	11-655006-000	Fitting (3/4-16 to 3/8 NPT)
27.	14-100802-000	Bracket - Conditioner Pump/Filter
28.	11-655043-022	Tube (3/8 x 13.5")
29.	14-100755-000	Conditioner Pump w/Fitting Assembly
30.	11-191753-000	Washer (1/4)
31.	11-170005-015	Lock Nut (#10-24)
32.	11-006061-015	Button Head Socket Cap Screw (#8-32 x 3/8")
33.	11-199002-015	Lockwasher - Internal Tooth (#8)
34.	11-655058-000	Tool Holder
35.	11-185257-000	Standoff (#8-32 x 1-1/4")
36.	11-199003-015	Lockwasher - Internal Tooth (#10)
37.	11-199005-015	Lockwasher (1/4)
38.	11-006178-001	Button Head Cap Screw (1/4-20 x 1/2")
39.	11-625600-000	"O" Ring
40.	11-655029-001	Filter
41.	11-655088-000	Compression Fitting (3/8 Tube x 3/8 NPT)
42.	11-655007-000	Accumulator Diaphragm
43.	11-655089-000	Fitting - male (3/8 Tube x 3/8 NPT)
44.	11-655040-000	Swivel Elbow - male
45.	14-100323-000	Injector
46.	14-100995-000	Conditioner Rail w/Connector Assembly
47.	14-100071-000	Rail - Accumulator
48.	11-655024-001	Top
49.	11-696944-000	Coolant Temperature Sensor
50.	11-655089-000	Fitting Straight (3/8 Tube x 3/8 NPT)
51.	14-100783-000	24VDC Solenoid Valve Assembly
52.	14-100784-000	24VDC Conditioner Tank Vent Valve
53.	14-100788-000	Conditioner Rail Heater
54.	14-100803-051	Conditioner Filter Assembly
55.	14-100790-000	Conditioner Tank - only
56.	11-006093-009	Button Head Socket Cap Screw (#10-32 x 7/8")
57.	14-101436-000	Conditioner Tube Clamp
58.	11-170005-015	Locknut (#10-24)
59.	14-101438-000	Tube to Harness Connector
60.	11-655053-000	90° Fixed Elbow (3/8)
61.	11-655043-006	Tube (3/8 x 3")
62.	11-655024-003	Gasket
63.	11-655024-002	Low Profile Bowl (White)
64.	11-655024-004	Filter - Cyl 40 x 300SS

Conditioning Delivery System

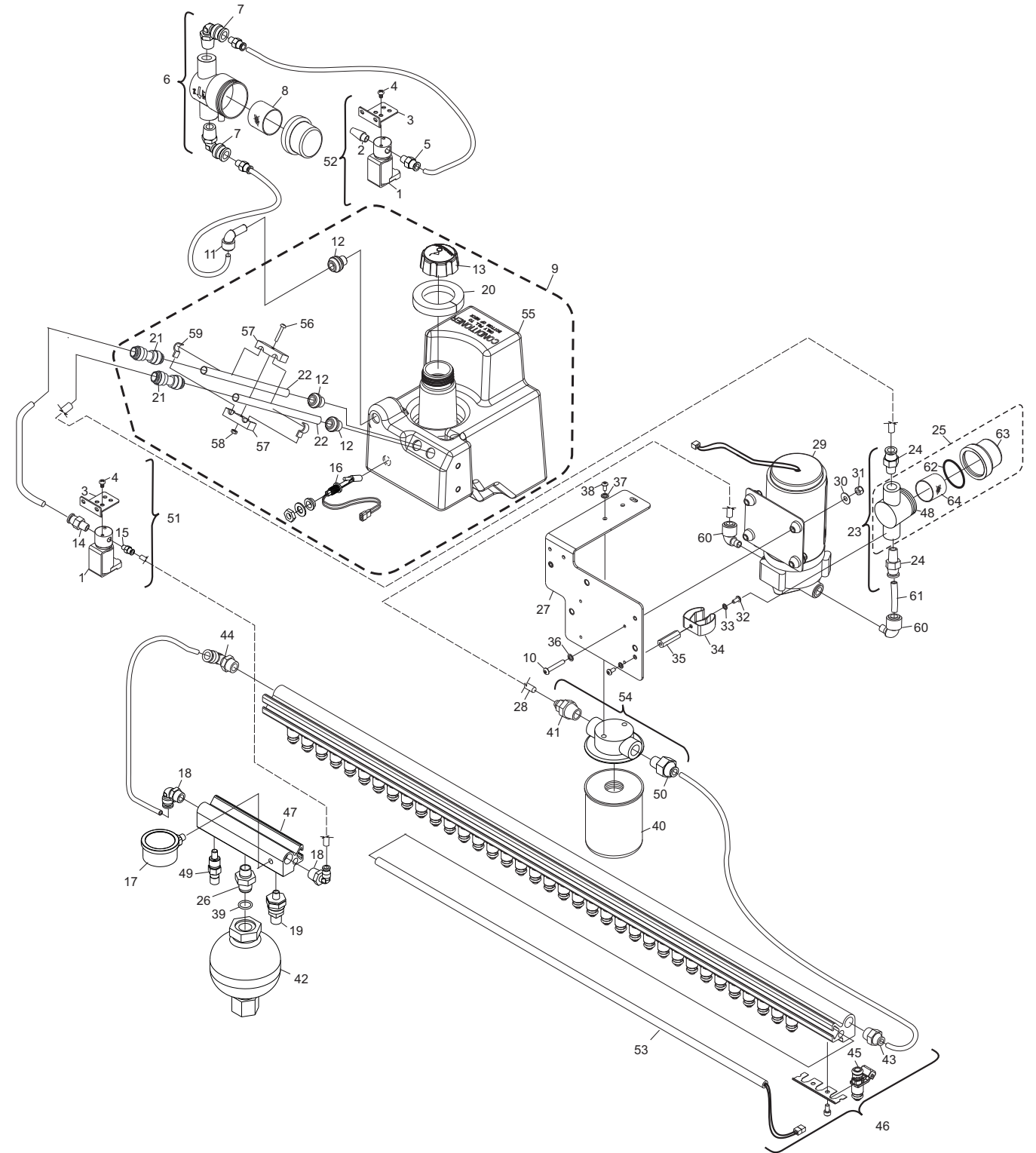

Conditioning Delivery System

**Index
No.**

Part No.

Description

1.	14-100057-000	Idler Pulley Mount
2.	14-100056-000	Idler Puller Tension Adjuster
3.	11-106554-009	Socket Head Shoulder Screw (5/16-18 x 3/8 Dia. x 1")
4.	11-655032-000	Shaft Collar (3/8")
5.	14-100800-000	Pivot Rod Assembly (long)
6.	14-100311-000	Shaft Coupler (3/8" to 3/8")
7.	14-100315-000	Pivot Rod Assembly (short)
8.	14-100796-000	Up/Down Linkage
9.	11-106550-009	Socket Head Shoulder Screw (5/16-18 x 3/8" Dia. x 3/8")
10.	11-191752-000	Nylon Washer (.390 I.D. x .75 O.D. x .062)
11.	11-125202-015	Nut (5/16-18)
12.	14-100044-000	Flange Mount Bearing Assembly
13.	14-100042-000	Gear belt Pulley/Short Shaft Assembly
14.	14-100793-000	Buffer Up/Down Motor Assembly
15.	14-100258-000	Up/Down Motor Cable Assembly
16.	14-100795-000	Buffer up/Down Motor Frame Bracket Assembly
17.	11-616026-000	Switch
18.	11-006010-000	Button Head Cap Screw (#4-40 x 1")
19.	11-199000-015	Internal Tooth Lock Washer (#4)
20.	14-100724-022	Gear Motor w/Connector (Buffer Up Down)
21.	11-006125-000	Button head Socket Cap Screw (#10-32 x 1")
22.	11-199003-015	Internal Tooth (#10) Lockwasher
23.	14-100258-000	Up/Down Switch Cable Assembly
24.	11-105454-000	Set Screw (1/4-28 x 3/8")
25.	14-100729-000	Buffer Up/Down Cam
26.	14-100043-000	Buffer Brush Assembly
27.	11-601010-000	Roller Chain
28.	14-100070-000	Dispersion Roller Assembly
29.	14-100111-000	Dispersion Roller Idler Pulley
30.	14-100202-000	Grease Fitting
31.	11-491104-000	Sprocket - 23 Tooth (3/8" bore)
32.	11-105451-000	Set Screw (#10-32 x 1/4")
33.	11-006125-000	Hex Head Socket Screw (#10-32 x 1")
34.	11-199003-015	Internal Tooth Lockwasher (#10)
35.	14-100762-000	Dispersion Roller Motor Bracket
36.	14-100724-050	Gear Motor w/Connector Assembly (Dispersion Roller)
37.	11-171504-000	Nut (1/4-20)
38.	10-621013-000	Key - Square (1/8" x 1")
39.	11-010782-000	Hex Serrated Head Cap Screw (1/4-20 x 1/2")
40.	14-100434-000	Buffer Brush Shield w/Felt Assembly
41.	11-655073-000	Gear Belt (28.5")
42.	14-100744-000	Buffer Brush Motor w/Connector
43.	14-100747-000	Gear Belt Pulley - 24 Teeth
44.	14-100794-000	Buffer Cam and Switch Bracket
45.	14-100567-000	Buffer Belt Tensioner Pulley
46.	11-600010-000	Chain Link
47.	11-680302-000	Terminal - Pin
48.	11-680116-000	Connector Housing
49.	14-100433-000	Buffer Shield Felt
50.	14-100426-000	Buffer Shield Guard
51.	14-100427-000	Buffer Shield Drip Foam
52.	*14-100557-000	Buffer Shield HP V-Shape Drip Foam
53.	11-696701-000	Connector Housing
54.	11-696736-000	Terminal
55.	11-199005-015	Lockwasher (1/4)
56.	11-006221-000	Screw (1/4-28 x 3/4")
57.	11-005308-000	Hex Socket Head Cap Screw (5/16-24 x 1-3/4")

* Not Illustrated

Conditioner Buffing System

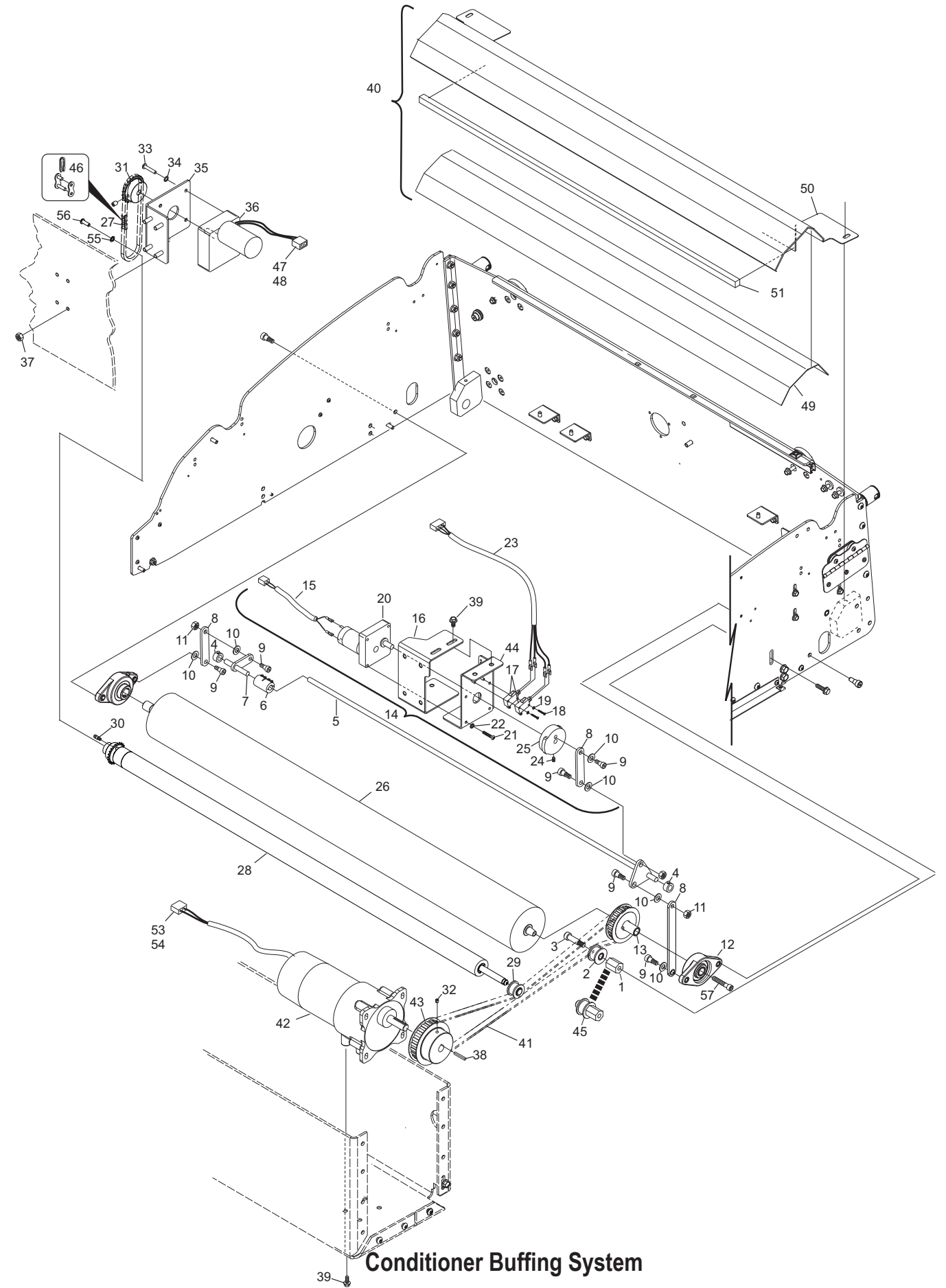

Intentionally Blank Page

Section D

Cover & Handle System

No.	Index Part No.	Description
1.	*14-101742-xxx	Top Cover Assembly (right-hand)
2.	*14-101572-xxx	Top Cover - only (right-hand)
3.	11-170006-015	Locknut (#10-32)
4.	11-190006-015	Flat Washer (#10)
5.	14-100358-000	Magnet Catch Plate
6.	11-170004-015	Locknut (#8-32)
7.	11-210007-000	Gas Spring Bracket
8.	*14-100964-xxx	Decal
9.	14-102003-000	Cover Latch Assembly
10.	14-101735-000	Rear Cover w/Logos Assembly
11.	14-101736-000	Rear Cover- only
12.	14-101030-000	Max Direct Logo
13.	14-101035-000	Brunswick Max Logo
14.	11-532004-009	External Retaining Ring (25 mm)
15.	*14-101740-xxx	Top Cover Assembly (left-hand)
16.	*14-101573-xxx	Top Cover - only
17.	11-112201-000	Latch Assembly
18.	14-100738-000	Side Cover (right-hand)
19.	14-100737-000	Side Cover (left-hand)
20.	11-054301-015	Cover Pin (front)
21.	14-100875-001	Cover Pin (rear)
22.	14-100875-002	Cover Pin (middle)
23.	14-100876-000	Cover Pin (guide)
24.	11-199002-015	Lockwasher (#8)
25.	11-006063-009	Button Head Cap Screw (#8-32 x 1/2")
26.	11-210008-000	Gas Spring (10lb. force)
27.	14-100373-000	Shim
28.	11-006127-000	Button Head Cap Screw (#10-32 x 1-1/4")
29.	11-192028-000	Spacer(nylon)
30.	14-100312-000	Hinge Nut Plate

* Color Codes

BLACK	001
GREEN	002

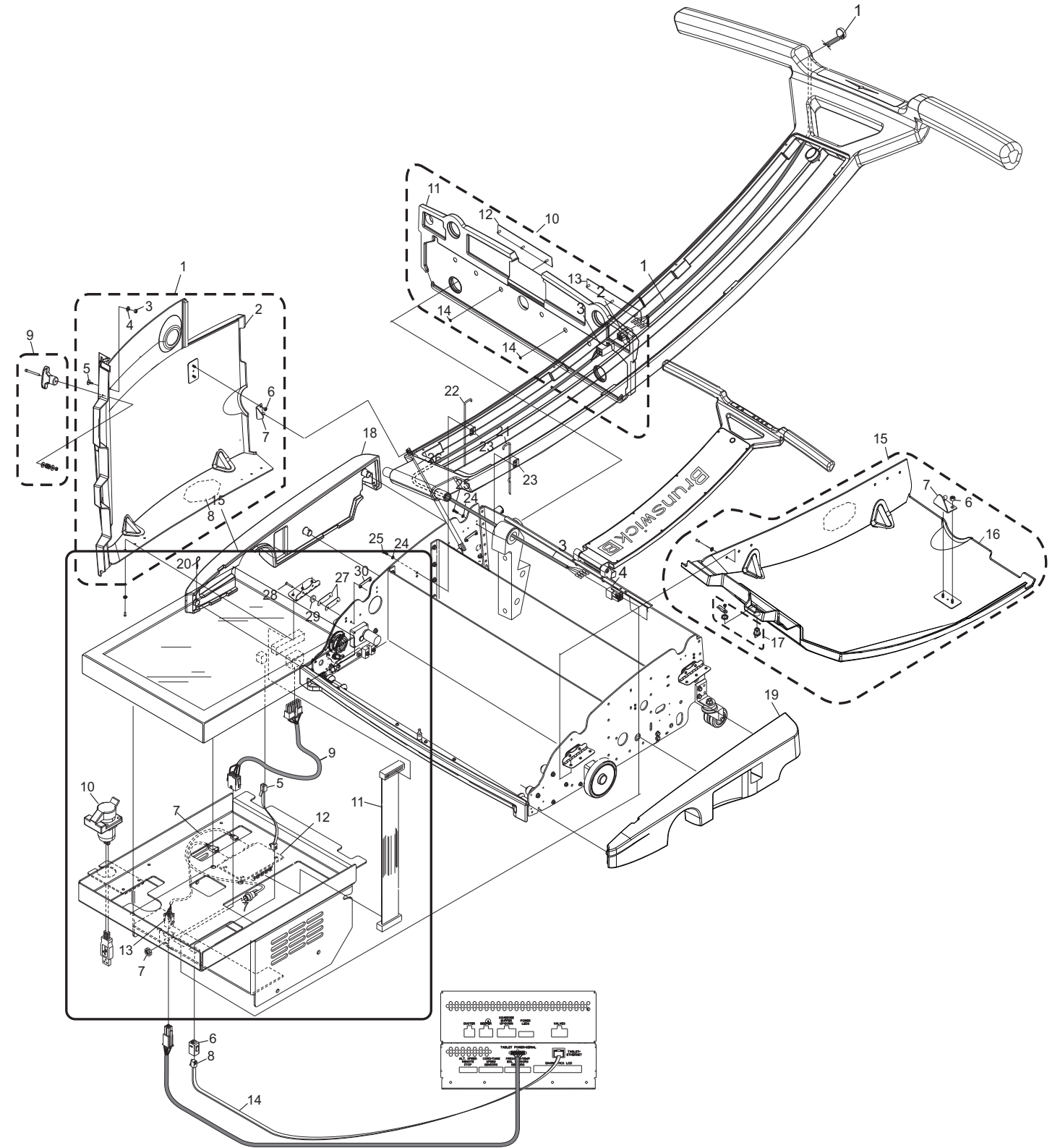

Hood System

Hood System

Index

No.	Part No.	Description
1.	14-101130-000	Handle w/Hinge Pins
2.	14-101132-000	Assembly, T-Handle Complete
3.	14-100376-001	Handle Cover Plate
4.	11-637202-000	Magnet
5.	11-004996-000	Socket Head Cap Screw (M4 x 12 mm)
6.	14-100142-000	Over Travel Block (lower)
7.	14-100012-001	Handle Grip
8.	14-100415-001	Decal - Raised Brunswick
9.	11-581050-000	Spring
10.	14-101137-000	Emblem
11.	14-101186-000	Cable - Button to Tablet
12.	11-014267-000	Flat Hd. C.R. Screw (#4-40 x 1/4")
13.	14-100941-000	Decal
14.	11-005272-015	Socket Head Cap Screw (5/16-18 x 2")
15.	11-010789-000	Hex Head Serrated Flange Screw (5/16-18 x 1-1/4")
16.	14-100134-002	Handle Hinge Bracket (left hand)
17.	14-100134-001	Handle Hinge Bracket (right hand)
18.	11-010783-000	Hex Head Serrated Flange Screw (5/16-18 x 3/4") Assembly
19.	14-100141-000	Over Travel Block (upper)
20.	84-200297-000	Double Sided Adhesive Foam Tape
21.	11-190012-015	Flat Washer (5/16")
22.	11-005353-015	Socket Head Cap Screw (3/8-16 x 2-1/4")
23.	11-680133-000	Connector Housing - 4 Position
24.	11-697856-000	Connector Housing - 8 Position
25.	14-101393-000	Lane Machine Button

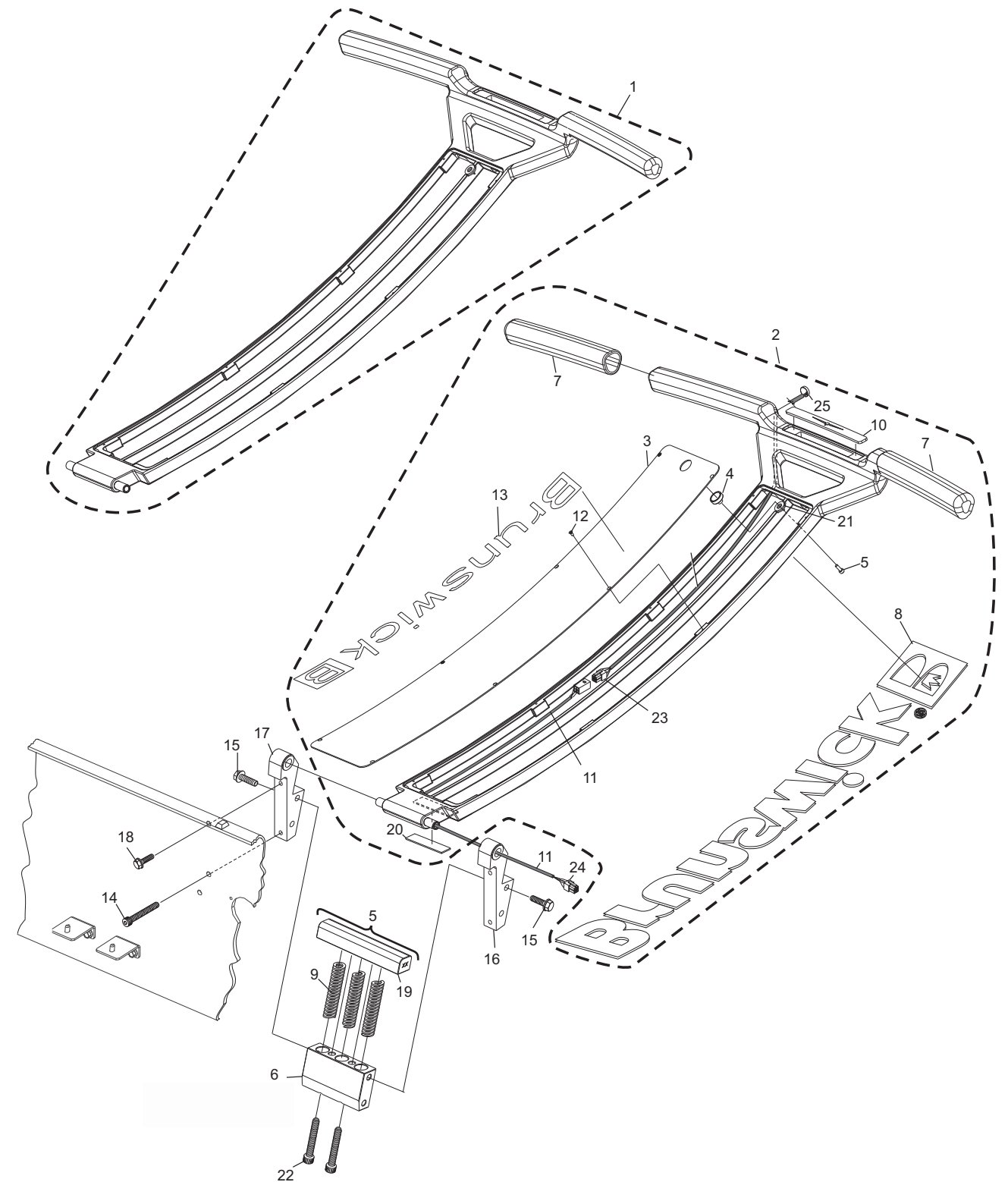

Handle System

Handle System

Intentionally Blank Page

Section E

Electrical System

Index No.	Part No.	Description
1.	14-101393-000	Cable Assembly - Button Lane Machine
2.	11-680133-000	Connector Housing - 8 Position
3.	14-101186-000	Cable Assembly - Button to Tablet
4.	11-697856-000	Connector Housing - 8 Position
5.	57-501416-001	Cable Assembly - Mini CAT5E, S5 Tablet
6.	11-681167-000	RJ-45 Coupler, CA5E
7.	14-101815-000	Cable Assembly - Power, Bracket to Interface Board
8.	14-101812-000	Power/Serial Tablet to Enclosure
9.	14-101814-000	Button Bracket to GPIO
10.	14-101816-000	USB Receptacle w/Cover and 12" Cable Assembly
11.	57-501412-000	Interface to S5 Tablet, Ribbon Cable Assembly
12.	57-501295-001	Interface PCB Assembly
13.	14-101813-000	Power/Serial Bracket to Interface - Cable Assembly
14.	57-501416-003	Mini CAT6, S5 Tablet Cable Assembly
15.	14-101842-400	MAX Tablet Assembly - Complete

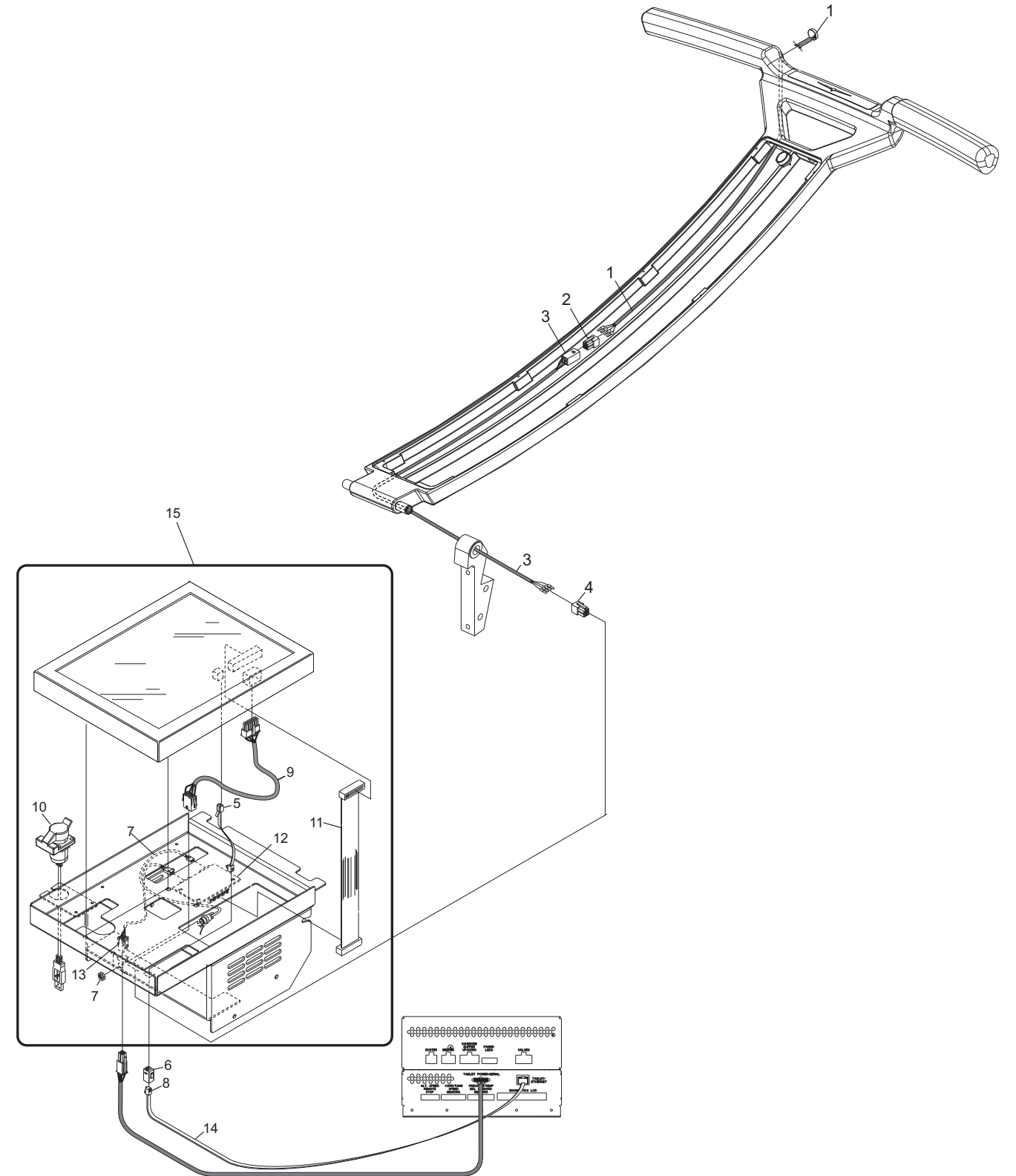

Tablet Interface

Tablet Interface

**Index
No.**

Part No.

Description

1.	11-900717-000	Decal - Emergency Stop
2.	14-100450-000	Decal - CRC and Warranty Contact
3.	14-100552-000	Decal - Cautions and Warnings, French
4.	14-100146-000	Decal - Cautions and Warnings
5.	14-101028-000	Assembly Emergency Stop Switch
6.	11-176005-015	Keps Nut (#6-32)
7.	11-012021-015	Screw Pan Head C.R. Int. (#6-32 x 1/4).
8.	11-176007-015	Keps Nut (#8-32)
9.	11-012022-015	Pan Head C.R. Screw (#6-32)
10.	11-672528-000	Power Relay (T9A)
11.	11-530031-015	Retaining Ring (external)
12.	14-100822-000	Regenerative Drive
13.	14-100583-000	V3.0 Injector Driver Board - Assembly
14.	14-101610-000	Motor Controller PCB, 24V LM
15.	14-101102-400	DC Lane Machine, Controller PCB - Assembly
16.	14-101014-400	Electrical Control Enclosure - Complete
17.	11-603142-000	Cable Clamp (7/16")
18.	11-170002-015	Locknut (#6-32)
19.	11-199002-015	Internal Tooth Lockwasher (#8)
20.	11-006061-015	Button Head Hex Cap Screw (#8-32 x 3/8")
21.	14-100907-000	Remote Stop Receiver and Controller
22.	14-100945-000	Audio Beep Indicator - Assembly
23.	11-012006-015	Screw w/Lockwasher (#4-40 X 1/2")
24.	14-101932-000	DC Controller PCB Remote Receiver Cable
25.	14-100160-000	Cord Kill Switch Sleeve
26.	14-100162-000	Cord Kill Switch Assembly
27.	11-616031-000	Switch
28.	11-006007-000	Button Head Cap Screw (#4-40 x 5/8")
29.	11-170000-015	Nut (#4-40)
30.	14-100161-000	Switch Bracket
31.	14-100267-000	Cord Kill Stud Assembly
32.	14-100159-000	Cord Kill Switch
33.	11-696006-000	Thermal Circuit Breaker (25 Amp)
34.	11-581012-000	Spring
35.	11-900004-015	Flat Washer (#8)
36.	11-003078-001	Socket Head Cap Screw (#8-32)
37.	11-185323-000	Stand-Off M/F (#6-32 x 3/4")
38.	11-672529-000	Relay

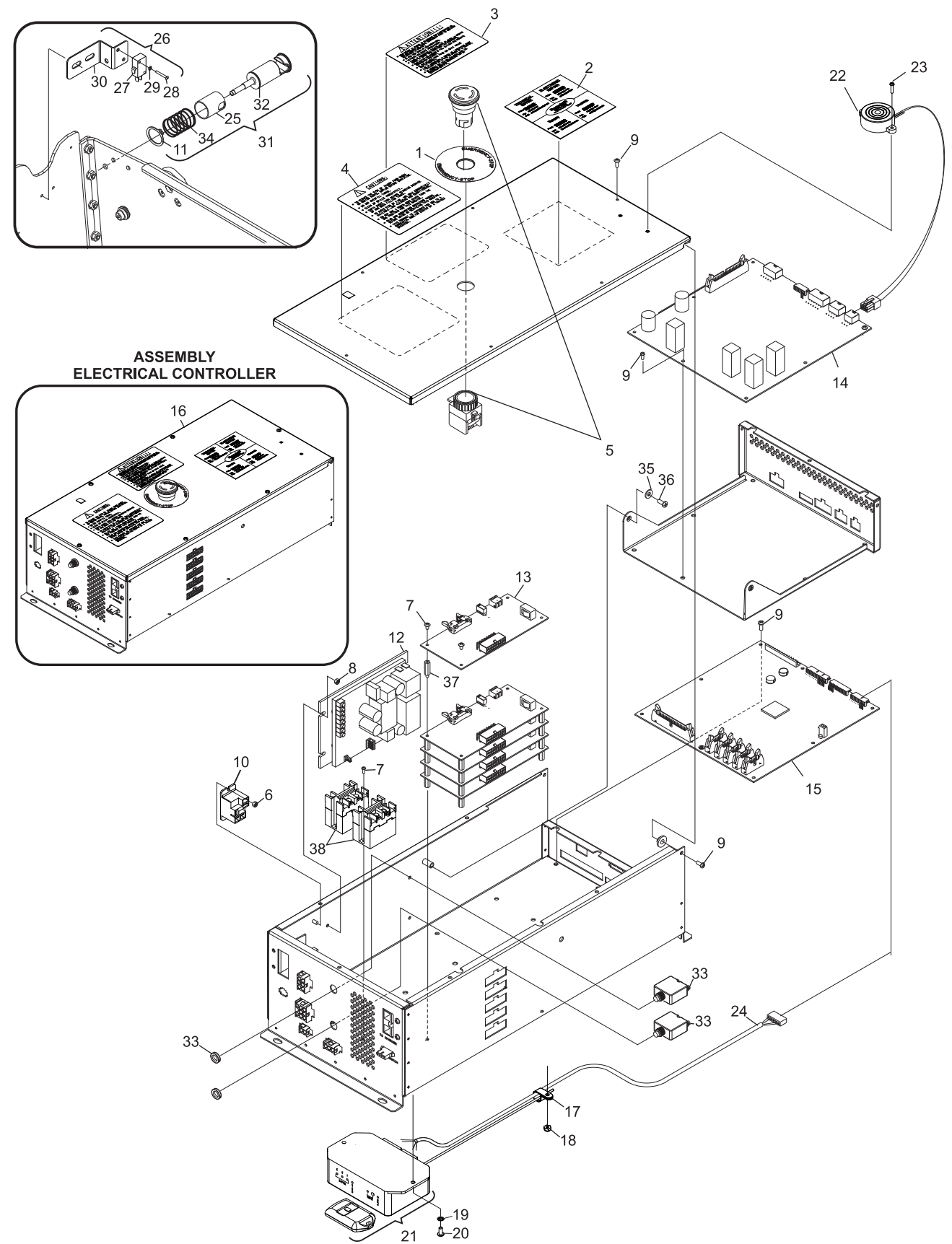

Electrical Enclosure

Electrical Enclosure

Index No.	Part No.	Description
1.	11-006120-015	Screw (#10-32 X 5/8")
2.	11-190006-015	Plain Washer (#10)
3.	14-100893-000	Battery Clamp
4.	14-101957-***	Lithium Battery w/Cable
5.	14-100924-115	(115V) Battery Charger w/Cables - 115V (includes Index Nos. 7, 8, and 10)
6.	14-100924-230	Battery Charger w/Cables -230V (includes Index Nos. 7, 9, and 10)
7.	14-100973-000	DC Cable Assembly
8.	14-100967-115	115VAC, Cable Assembly - Battery Charger
9.	14-100967-230	230VAC, Cable Assembly - Battery Charger
10.	14-100968-000	N.A. Battery Charger - not available separately R.O. Order Index No. 5 or Index No. 6

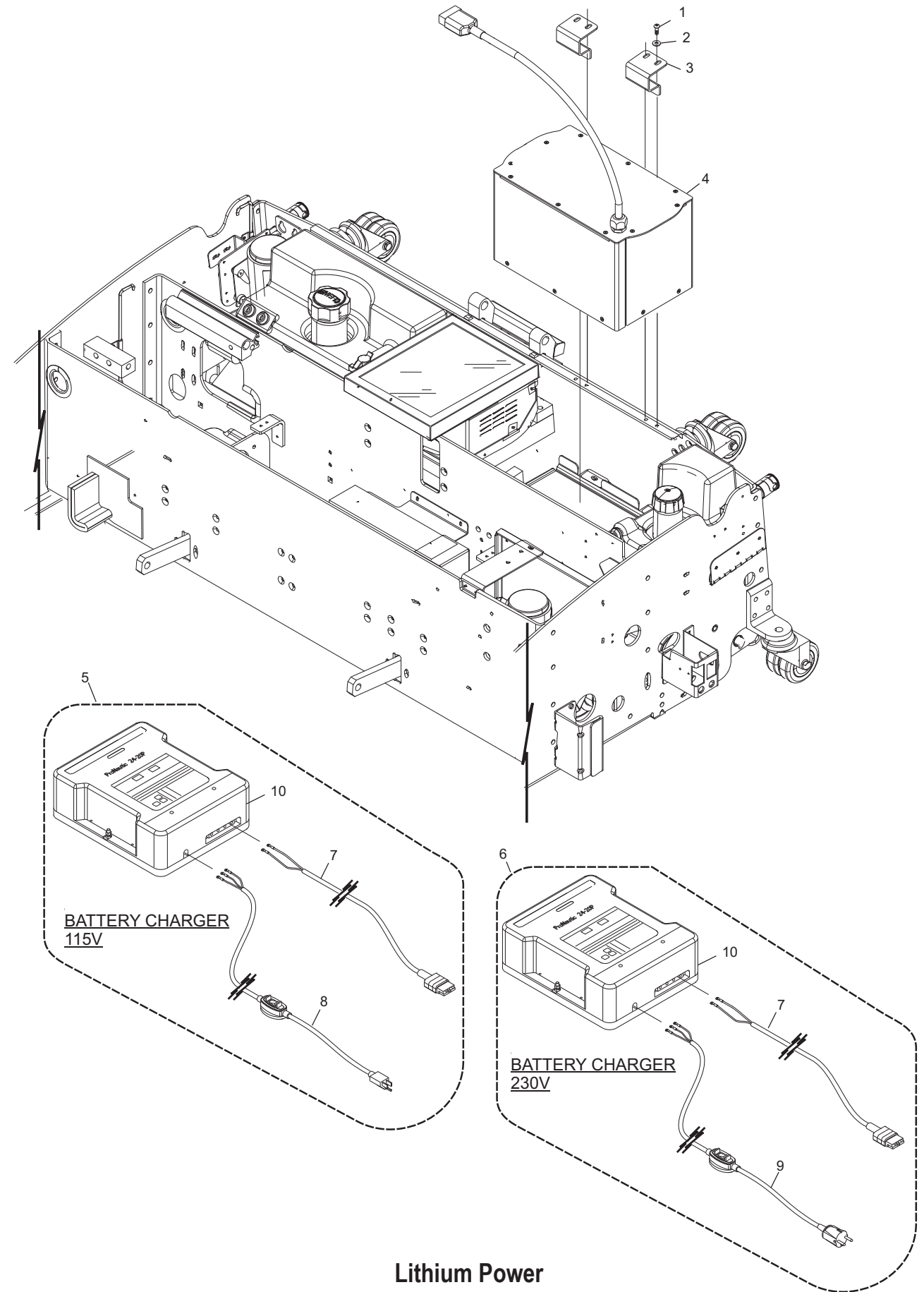

Lithium Power

Lithium Power

Index No.	Part No.	Description
1.	14-101948000	AC/DC Power Supply and Mount Bracket Assembly
2.	11-056006-015	Button Head Screw w/External Tooth Washer (M4 x 6 mm)
3.	11-615132-000	Locknut (1/2 NPT)
4.	14-101957-001	AC/DC Power Supply Cable
5.	14-101950-000	Splash Guard
6.	14-101888-000	Input Power to Power Supply Cable Assembly
7.	14-101036-000	AC/DC Power Supply Sensing Cable Assembly
8.	14-100947-000	Power Supply Bracket

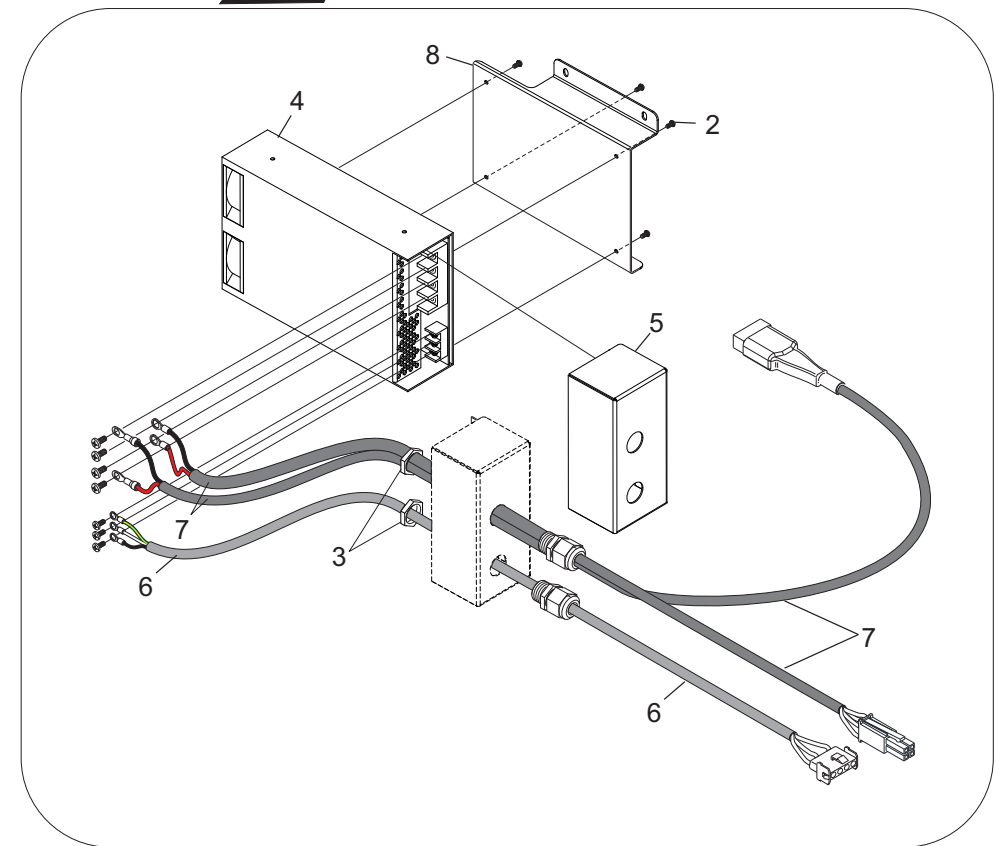
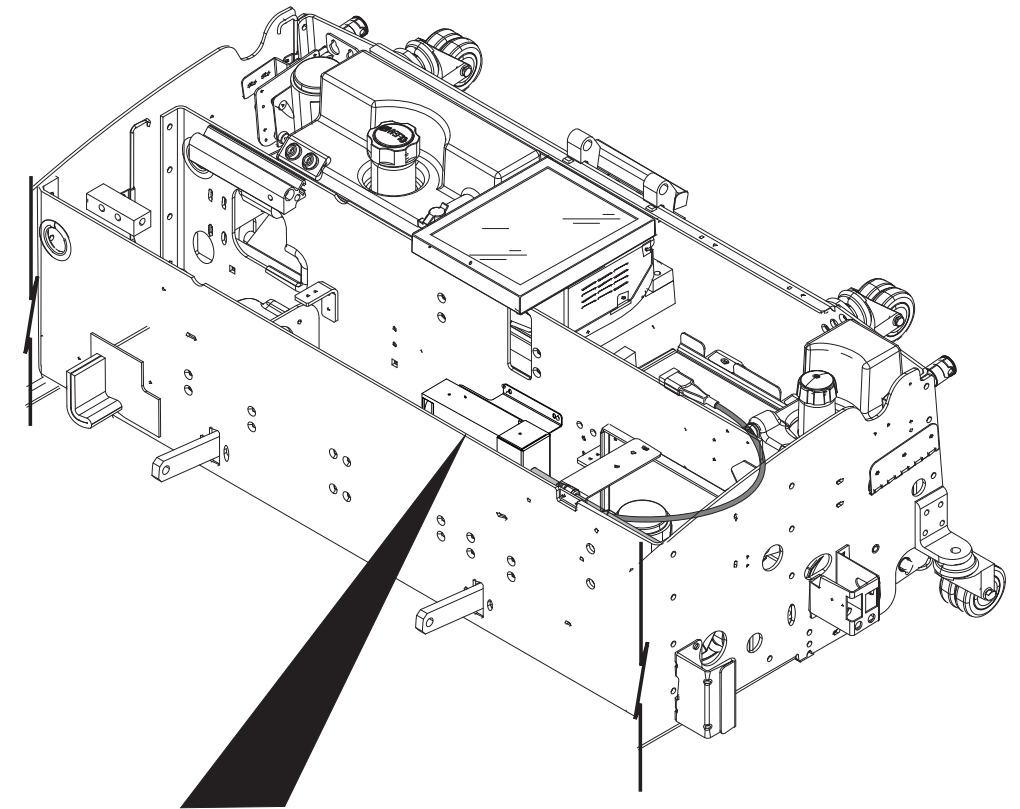

AC/DC Power

AC/DC Power

Index No.	Part No.	Description
1.	14-100813-000	Vacuum Motor, (DC), External Cable Assembly
2.	14-100885-000	Dispersion/Buffer Brush Cable Assembly
3.	14-100886-000	Oil/Cleaner Pumps/Oil Heater Cable Assembly
4.	14-100891-000	Power Switch Cable Assembly
5.	14-100815-000	DC Charging Port (SB50) Cable Assembly
6.	11-615189-000	Rocker Switch
7.	11-006045-015	Button Head Cap Screw (#10-32 x 1/2")
8.	11-680076-000	LED, Blue (12V)
9.	11-680046-000	LED, Green (12V)
10.	11-170002-015	Locknut (#6-32)
11.	11-006118-015	Button Head Cap Screw (#10-32 x 1/2")
12.	11-199003-015	Button Head Cap Screw (#10-32 x 1/2")
13.	14-100847-000	Charging Port Indicator Lights Bracket

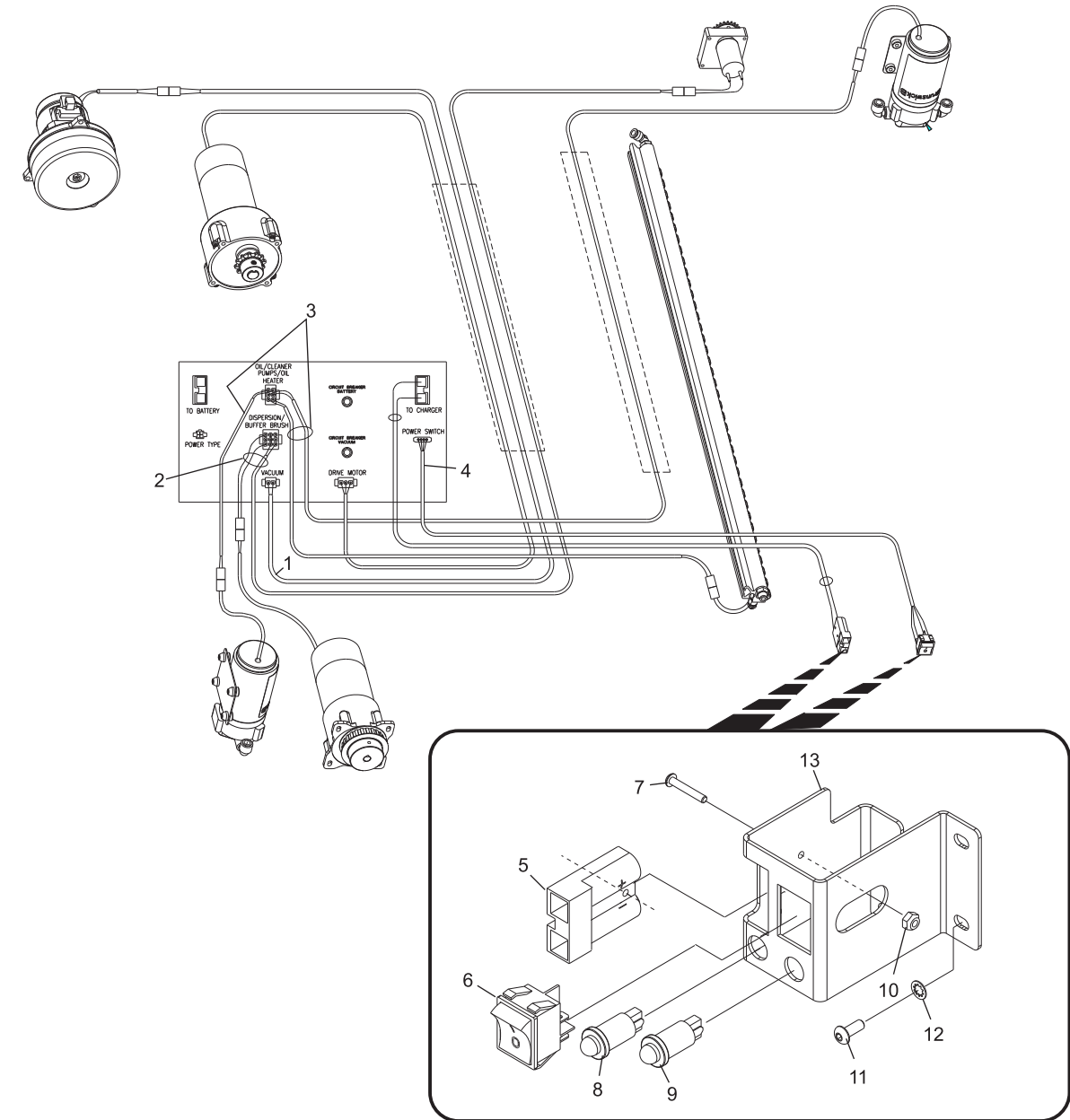

Electronic Enclosure - Left Side Video - Cable Assemblies

Electronic Enclosure - Left Side Video - Cable Assemblies

Index No.	Part No.	Description
1.	14-100884-000	Duster Motor Cable Assembly
2.	14-101883-000	Squeegee/Buffer Up Down Cable Assembly
3.	14-100927-000	Power/Charger LEDs Cable Assembly
4.	14-100846-000	Conditioner Vent/Pressure Valves Cable Assembly
5.	14-101811-000	Temperature/Pressure/EOL Sensors Cable Assembly
6.	14-101810-000	Float/Cord Kill/Speed Sensor Cable Assembly

Electronic Enclosure - Right Side Video - Cable Assemblies

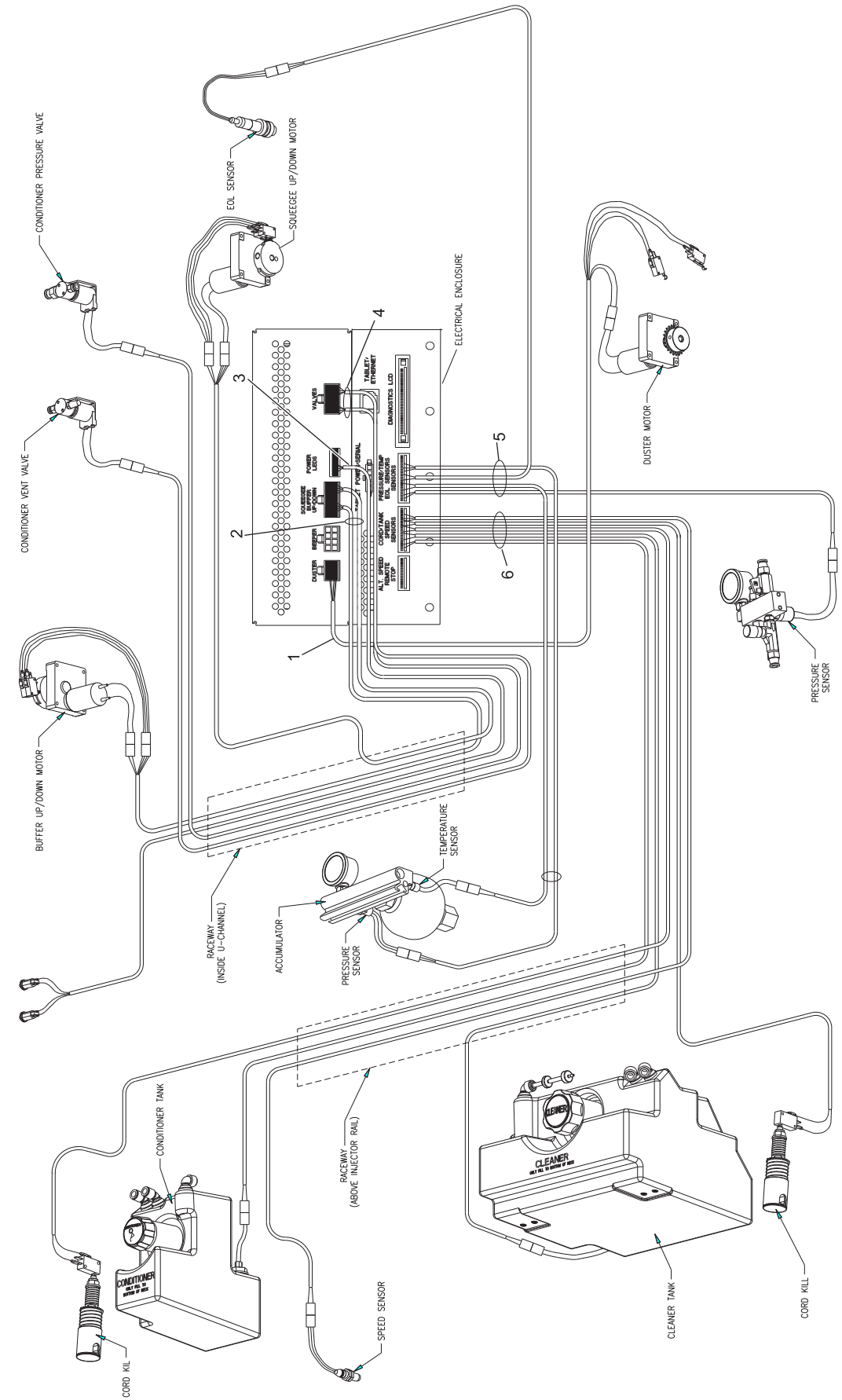

Electronic Enclosure - Right Side Video - Cable Assemblies

Index No.	Part No.	Description
1.	14-100834-001	1-8 Injectors to Board Cable Assembly
2.	14-100834-002	9-16 Injectors to Board Cable Assembly
3.	14-100834-003	17-24 Injectors to Board Cable Assembly
4.	14-100834-004	25-32 Injectors to Board Cable Assembly
5.	14-100834-005	33-39 Injectors to Board Cable Assembly

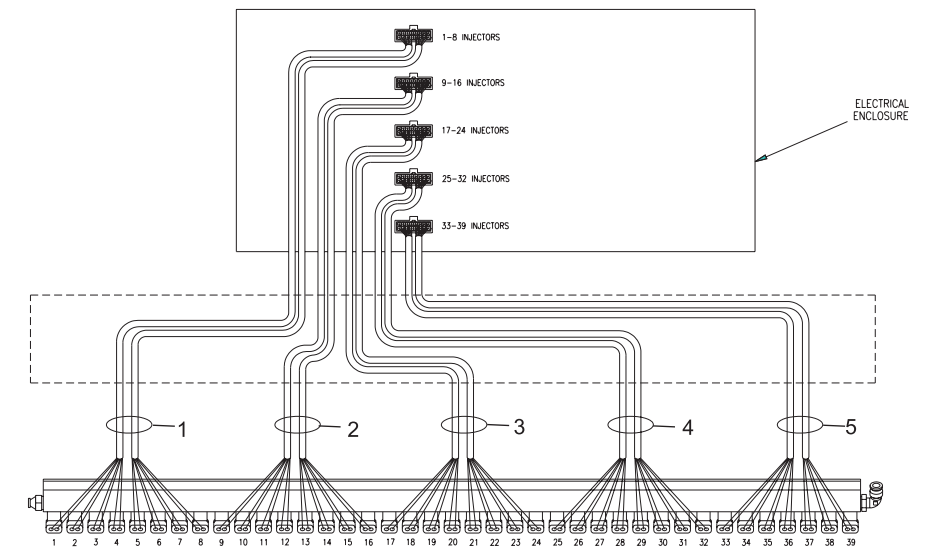

Electronic Enclosure - Rear View - Cable Assemblies

Electronic Enclosure - Rear View - Cable Assemblies

Index

No.	Part No.	Description
1.	11-696749-000	Twist-Lock Connector (250V)
2.	11-603135-000	Split Ring (1.159 I.D.)
3.	11-617079-000	Heat Shrink (6")
4.	11-617076-001	Braided Sleeving
5.	11-617077-002	Heat Shrink (40")
6.	14-860208-024	Power Cord (115V)
	14-860208-224	Power Cord (240V)

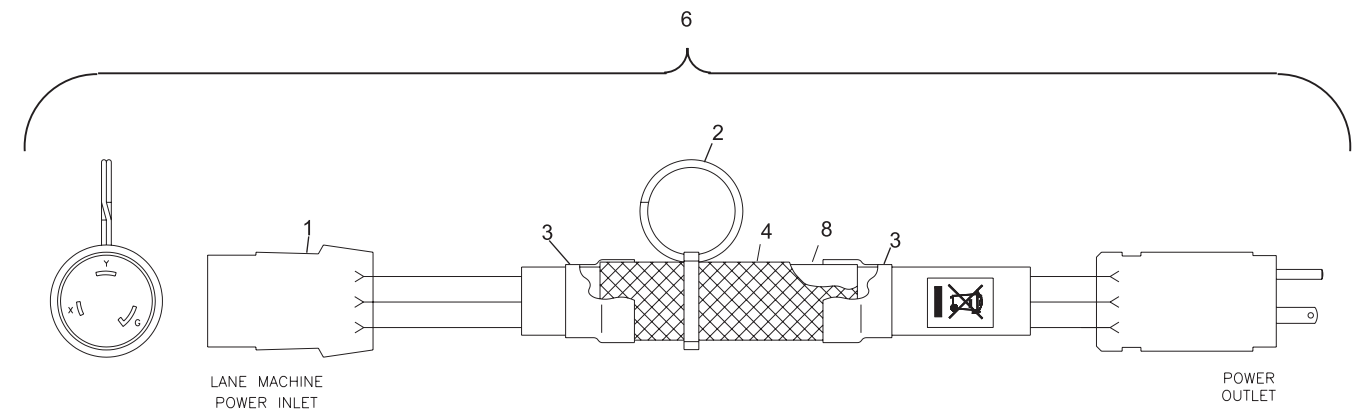

Power Cord

Power Cord

Intentionally Blank Page

Section F

Miscellaneous

Index		
No.	Part No.	Description
1.	14-860214-000	Pkg-Fuse, 4.0A, 250V Slow 5 mm x 20 mm
2.	14-860242-000	Pkg- Fuse, 20A, 250V Slow, 5 mm x 20 mm
3.	14-860216-000	Pkg- Fuse, 10A, 250V Slow, 5 mm x 20 mm
4.	11-685134-000	Fuse, 40A, Maxi
5.	14-860218-000	Pkg- Fuse 6.3A, 250V Slow, 5 mm x 20 mm
6.	14-860219-000	Pkg-Fuse, 1.25A, 250V Slow, 5 mm x 20 mm
7.	11-112134-000	Tool - Dual Fuse Remover
8.	57-901001-000	Uni-Mate Extraction Tool (.093)
9.	57-900102-000	Molex Round Extractor (.062)
10.	57-900104-000	AMP Extractor #18040301 (1 Round)
11.	57-900112-000	Molex Mini-Fit Extraction Tool
12.	57-901002-000	Molex Micro-Fit 3.0 Extraction Tool
13.	11-696736-000	Pins (Uni-Mate)
14.	11-696737-000	Sockets (Uni-Mate)
14.	11-680302-000	Pkg. of 10 Pins (.062)
16.	11-680301-000	Pkg. of 20 Sockets (.062)
17.	11-680316-000	Sockets (Micro-Fit 3.0)
18.	11-692091-000	Pkg of 10 Sockets (Mini-Fit Jr)
19.	11-612153-000	Fast-ons (.250)
20.	11-680328-000	Terminals (.156 kk)
21.	57-900103-000	Crimp Service Tool
22.	11-680309-000	Brass Terminal Loose (.062)

Fuses/ Extraction Tools/ Pins & Sockets

Index		
No.	Part No.	Description
1.	11-655043-006	Tube (3/8" OD x .295 ID x 20')
2.	11-655013-010	Tube (1/4" OD x .170 ID x 20')
3.	11-655039-007	Cleaner Vent Tube (1/4" OD x 20')
4.	14-101092-000	Gage (Depth, Squeegee/Buffer Brush)
5.	11-112132-000	Long T-Handle Allen Wrench (1/4")
6.	11-112133-000	Screwdriver (#2 Phillips 10" Shank)
7.	11-676692-000	Loctite Metal Pipe (#567)
8.	11-676693-000	Loctite Threadlocker (#262 Red 10MI)
9.	11-676696-000	Loctite Threadlocker (#242 Blue 10MI)
10.	11-900080-000	Teflon Tape (Tread Seal 1/2X260")
11.	14-101263-000	AC Input Adapter (Tablet, GUI)
12.	57-861288-000	Package Line Cord, 7-1/2"
13.	14-860209-000	Pkg.- Cleaning Mixing Vessel No Spill
14.	14-860252-000	Pkg.- Spare Parts Kit
15.	14-900107-000	MAX Operator's Manual
16.	14-900106-000	MAX Service Parts Manual

Tubing/Tools/Miscellaneous

Intentionally Blank Page